

Actuator

AMK35

AMK35 is an intelligent actuator with a control board inside. Its robust mechanical design provides up to 10,000N thrust and is IP66/67/69K ingress protection rated. A variety of performance and control options are available to suit the user's application. AMK35 is ideal for applications such as agriculture, construction and industrial automation.



Features

- Main applications: Agriculture, Construction and Industrial Automation.
- Spindle type: Ball screw
- Input voltage: 12V DC / 24V DC (It is forbidden to use Pulse Width Modulation (PWM) as input power)
- Max. load: 10,000N (Push/Pull)
- Max. static load: 18,000N (Push)
- Speed at no load: 63mm/sec (Typical value of gear ratio 5:1)
- Stroke: 100 ~ 1,000mm (The max. stroke is depending on load, refer to Dimensions)
- Manual drive capable by an hexagon socket wrench
- Stainless steel extension tube
- IP level: IP66 (Dynamic) and IP67/IP69K (Static)
- Salt spray tested for 500 hours
- Built-in stroke limit switches
- Various control options to suit the user's application
- Duty cycle: 15 ~ 25%. Refer to Performance Data
- Operating ambient temperature: -40°C ~ +80°C (Full performance +5°C ~ +40°C)
- Certified: CE Marking, EMC Directive 2014/30/EU

Options

• DXX options (Traditional DC control)

Directly swap the polarity of the input power to control the extension and retraction of the actuator.

	D00	D0L	DPL	DHL	D+L
Potentiometer output ⁽¹⁾	-	-	✓	-	-
Hall signal output ⁽²⁾	-	-	-	✓	✓
EoS signal output ⁽³⁾	-	✓	✓	✓	✓
Over current protection ⁽⁵⁾	✓	✓	✓	✓	✓

• Signal Controls

Equipped with an H-bridge circuit to control the extension and retraction of the actuator. The motor is shorted when stopped during the whole stroke, as long as the actuator is powered.

	S0L	SPL	SHL	J00
Control platform	Low current signal	Low current signal	Low current signal	J1939 CAN Bus
H-bridge ⁽¹⁾	✓	✓	✓	✓
Potentiometer output ⁽²⁾	-	✓	-	-
Hall signal output ⁽³⁾	-	-	✓	-
EoS signal output ⁽⁴⁾	✓	✓	✓	-
Soft start/stop	✓	✓	✓	✓
Over current protection	✓	✓	✓	✓
Over voltage protection	✓	✓	✓	✓
Temperature monitoring ⁽⁵⁾	✓	✓	✓	✓
Status feedback	-	-	-	✓
Current feedback	-	-	-	✓
Position feedback	-	-	-	✓
Speed/ramp feedback	-	-	-	✓
Error code feedback	-	-	-	✓

Remarks:

- (1) A wire connection of voltage input (Vin) is required. The recommended voltage is 5~32V DC.
- (2) The Hall feedback circuit of DHL and SHL options is NPN type; the Hall feedback circuit of D+L option is PNP type.
- (3) End of stroke signal output is not potential free. An external 5~24V power and pull-up resistor are required. (10K ohm resistor is recommended)
- (4) The polarity of input DC power for the signal control options must be fixed and cannot be switched.
- (5) Over current protection: 25A @12V DC; 12.5A @24V DC, actuator will be stopped automatically.
Over current protection is only applicable in emergency situations. It should not be used for the normal routine stopping needs of the actuator, as this may damage the actuator.
- (6) Voltage protection: The allowable input voltage is 9~16V @12V DC; 18~32V @24V DC, if it exceeds the range, actuator will be stopped automatically.
- (7) When it is detected that the temperature is lower than 0°C, the overcurrent protection setting value will be automatically increased by 30%, which will reduce the over current protection caused by low temperature.

Performance Data

No.	Gear ratio	Push / Pull Max. (N)	Typical speed (mm/s) *		Typical current (A) *				Duty cycle
			No load	Full load	No load		Full load		
					24V	12V	24V	12V	
1	5:1	1,700	63	52	1.5	3.0	8.5	17	25%
2	10:1	2,600	38	30	1.5	3.0	8.0	16	25%
3	15:1	4,500	23	18	1.5	3.0	8.5	17	25%
4	20:1	6,800	17.5	13.5	1.5	3.0	9.0	18	25%
5	30:1	10,000	11	8.5	1.5	3.0	8.5	17	15%

Speed VS. Load

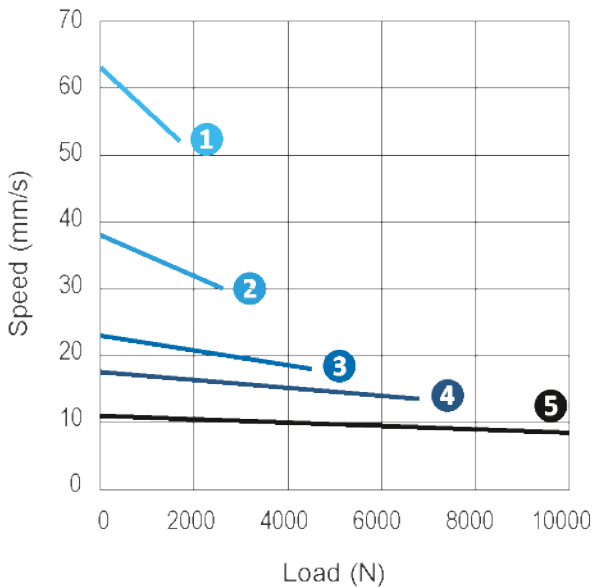

24V DC

Current VS. Load

12V DC

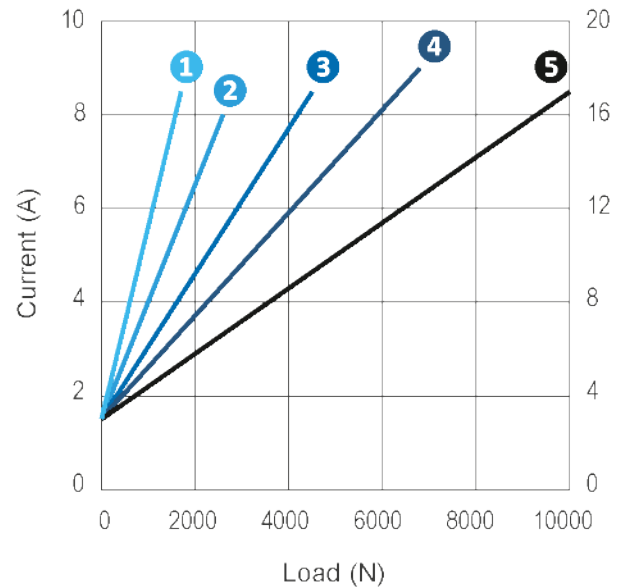

*** Remarks:**

1. The typical speed or typical current refers to an average value that is neither the upper limit nor the lower limit. The performance curves are made with typical values.
2. Stand-by current <math><20\text{mA}</math> (12/24V DC)

Dimensions

- Installation dimension (A)

Gear type	Solid connector	Slot connector	Available stroke (S)*	Max. load
05	$A \geq S + 190\text{mm} (\pm 4\text{mm})$	$A \geq S + 199\text{mm} (\pm 4\text{mm})$	100~1000 (+2/-6 mm)	$\leq 1,700\text{N}$
10				$\leq 2,600\text{N}$
15			100~800mm (+2/-6 mm)	$\leq 4,500\text{N}$
20			100~600mm (+2/-6 mm)	$\leq 6,800\text{N}$
30			100~500mm (+2/-6 mm)	$\leq 10,000\text{N}$

* Remarks: One step in every 50mm

- Drawing

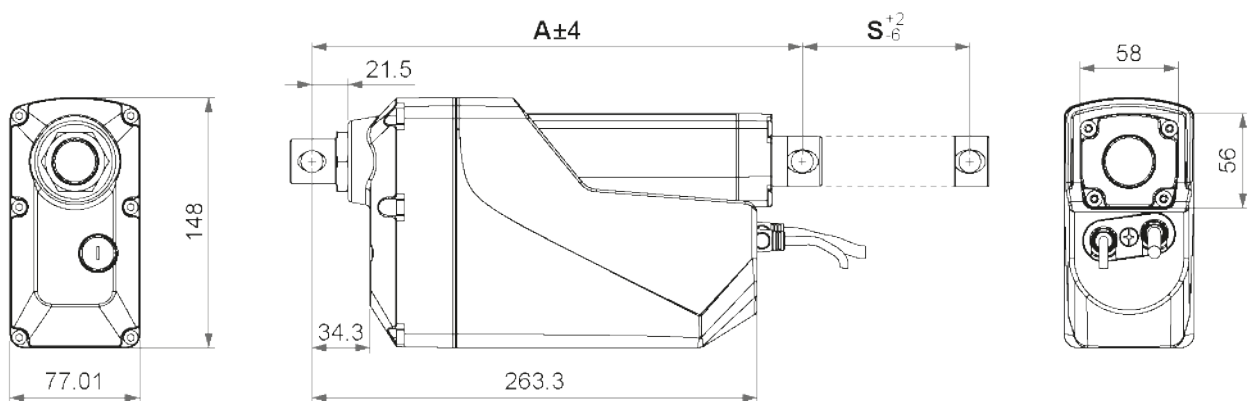

Unit: mm

● Front connector

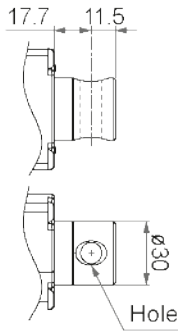

1 : Metal solid, hole \varnothing 12.2mm
3 : Metal solid, hole \varnothing 13mm

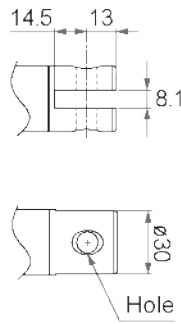

2 : Metal slot, hole \varnothing 12.2mm
4 : Metal slot, hole \varnothing 13mm

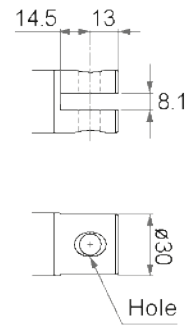

6 : SUS304 slot, hole \varnothing 12.2mm
8 : SUS304 slot, hole \varnothing 13mm

● Rear connector

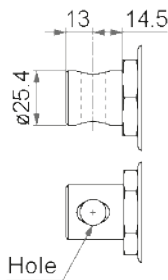

1 : Metal solid, hole \varnothing 12.2mm
3 : Metal solid, hole \varnothing 13mm

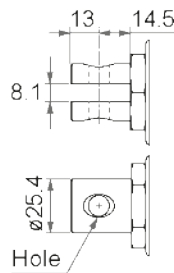

2 : Metal slot, hole \varnothing 12.2mm
4 : Metal slot, hole \varnothing 13mm

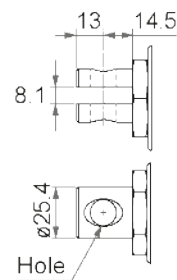

6 : SUS304 slot, hole \varnothing 12.2mm
8 : SUS304 slot, hole \varnothing 13mm

Unit: mm

● Connector orientation

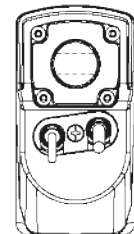
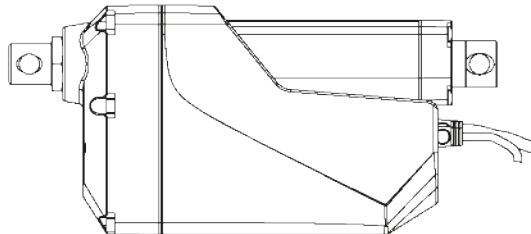
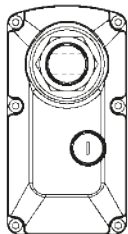

Note: Front and rear connectors shown in standard 0°

Certifications

AMK35 actuator is compliant with the following regulations, in terms of the essential conformity requirements of EMC Directive of 2014/30/EU.

Emission	Immunity
EN IEC 61000-6-3:2021	EN IEC 61000-6-1:2019

Ordering Key

AMK35 - 24 G5B 30 A00 J00 1 1 0 0 0 1

Input voltage	12 : 12V DC 24 : 24V DC
Motor and spindle type	G5B : 4500rpm / 5.08mm pitch / Ball screw
Gear ratio	05:5:1 20:20:1 10:10:1 30:30:1 15:15:1
Stroke	XXX: 100~950mm (one step in every 50mm); A00=1000mm
Control options	D00 : DC control, without positioning feedback. D0L : DC control + EoS DPL : DC control + Potentiometer + EoS DHL : DC control + Dual Hall effect sensors (NPN) + EoS D+L : DC control + Dual Hall effect sensors (PNP) + EoS S0L : Low current signal control + EoS SPL : Low current signal control + Potentiometer + EoS SHL : Low current signal control + Dual Hall effect sensors (NPN) + EoS J00 : J1939 CAN Bus
Front connector (Refer to Page 5)	1, 2, 3, 4, 6, 8
Rear connector (Refer to Page 5)	1, 2, 3, 4, 6, 8
Connector orientation (Refer to Page 5)	0 : 0° (standard) 9 : 90° <i>(Front and rear connectors shown in standard 0°)</i>
Reserved	0
Reserved	0
Cable length	1 : 500mm straight 5 : 1500mm straight 7 : 3000mm straight

Tel: +31 (0)85 0668800
Mail: verkoop@aamotionandcontrol.nl
www.aamotionandcontrol.nl



Terms of Use

The user is responsible for application suitability of A&A Motion and Control products. As ongoing improvement process continues, products listed on the A&A Motion and Control website are subject to change without prior notice. Moteck reserves the right to terminate the sales or remove any product displayed on the website, or listed in its catalogues.