

Actuator

AID10

AID10 features its heavy load capability and high speed design, which is suitable for various industrial applications requiring quick movement, such as agricultural and construction machine. Ball Screw or ACME spindle is available for users to choose.



Feature

- Main applications: Industrial
- Input voltage: 12 / 24 / 48V DC
- Max. rated load: 3,500N (ACME) / 7,000N (Ball Screw)
- Max. static load: 4,500N (ACME) / 13,600N (Ball Screw)
- Typical speed at no load: 72.1 mm/sec
- Stroke: 102 ~ 610 mm
- IP Protection level: IP65
- Overload protection by clutch
- Extension tube material: Iron (ACME) or stainless steel (Ball Screw)
- Color: Black
- Power cord length: 250mm (with tinned wires)
- Bottom cable outlet
- Duty cycle: 25%, max. 2 min. continuous operation in 8 min.
- Ambient operation temperature: -25°C ~ +65°C
- Certified: CE Marking, EMC Directive 2014/30/EU

Option

- Positioning signal feedback with Hall effect sensor x 1
- Analog and absolute positioning feedback with Potentiometer (POT)
- Preset limit switches (LT), to stop motor automatically at both stroke ends by cutting power.
- IP Protection level: IP65
- Manual drive connector (MD, can be driven by hand with a 8mm hex bit screwdriver or electric screwdriver)
- Thermal protection
- Mounting bracket (MB30) (*Fig. 1*)



Fig. 1

Performance Data

ACME type

• 12V DC motor

Model No.	Gear ratio	Push/Pull Max. (N)	*Typical Speed (mm/s)		*Typical Current (A)	
			No load	Full load	No load	Full load
AID10-12-10-A-XXX	10:1	1500	33.5	26.7	2.6	17.6
AID10-12-20-A-XXX	20:1	2500	16.8	14.3	2.6	13.2
AID10-12-40-A-XXX	40:1	3500	8.4	7.4	2.6	11.0

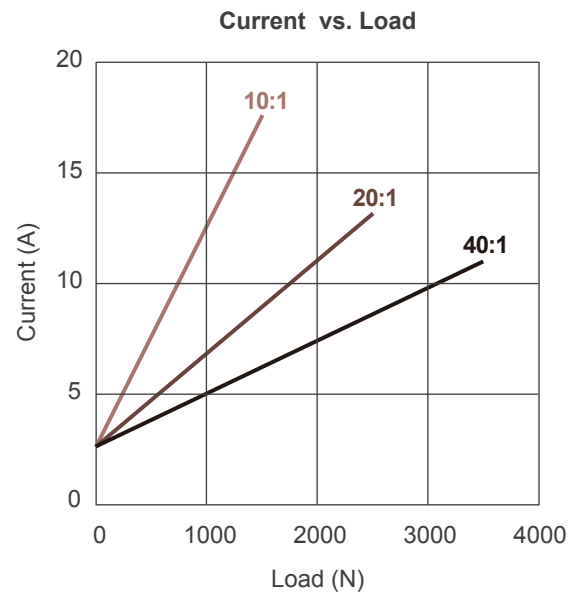
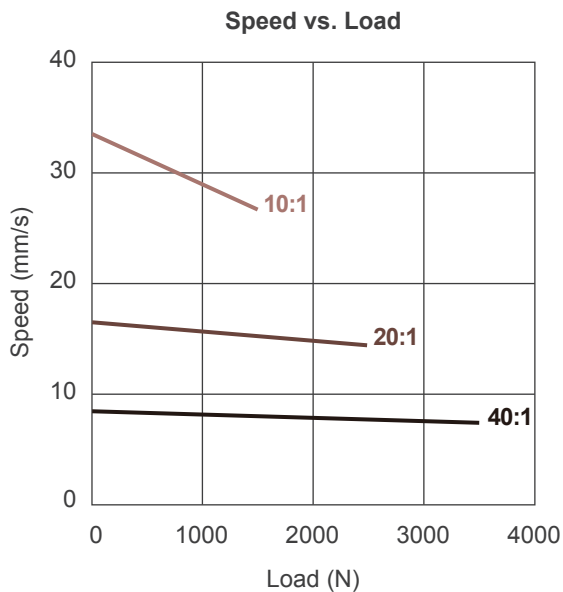

• 24V DC motor

Model No.	Gear ratio	Push/Pull Max. (N)	*Typical Speed (mm/s)		*Typical Current (A)	
			No load	Full load	No load	Full load
AID10-24-10-A-XXX	10:1	1500	33.5	26.7	1.6	8.8
AID10-24-20-A-XXX	20:1	2500	16.8	14.3	1.6	6.6
AID10-24-40-A-XXX	40:1	3500	8.4	7.4	1.6	5.5

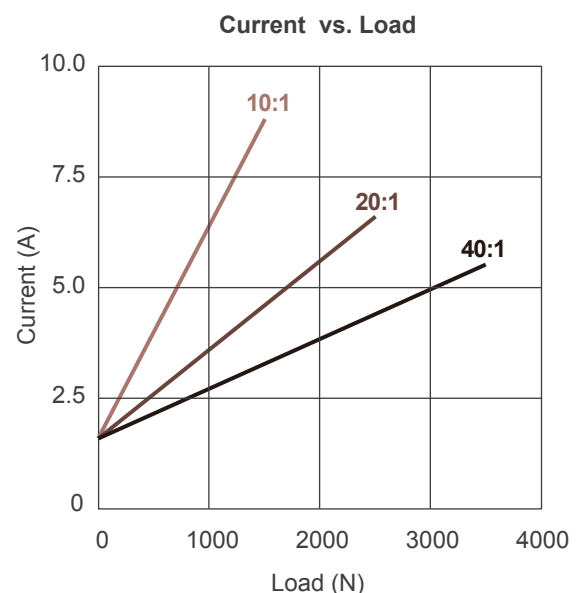
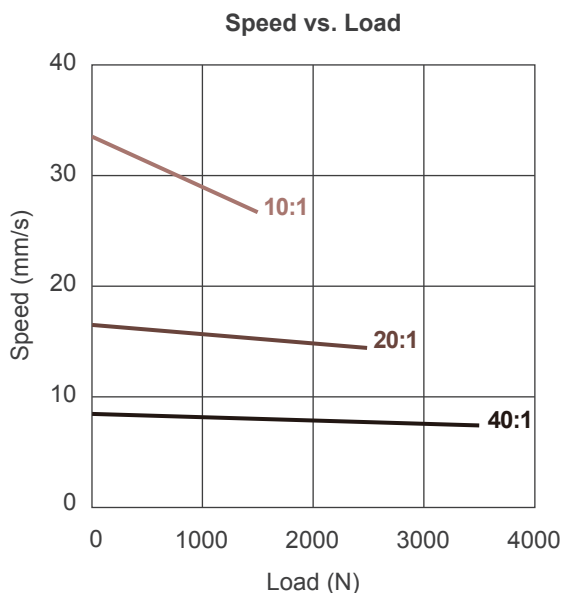

● 48V DC motor

Model No.	Gear ratio	Push/Pull Max. (N)	*Typical Speed (mm/s)		*Typical Current (A)	
			No load	Full load	No load	Full load
AID10-48-10-A-XXX	10:1	1500	36.5	29.1	1.4	3.6
AID10-48-20-A-XXX	20:1	2500	17.8	15.3	0.8	2.4
AID10-48-40-A-XXX	40:1	3500	8.6	7.8	0.5	2.1

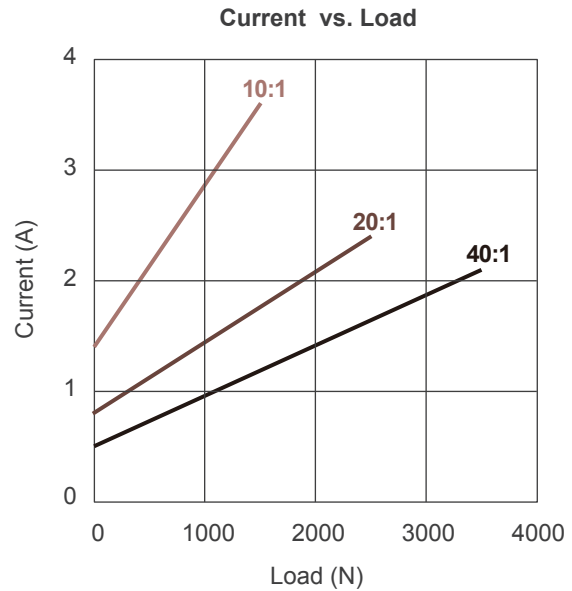
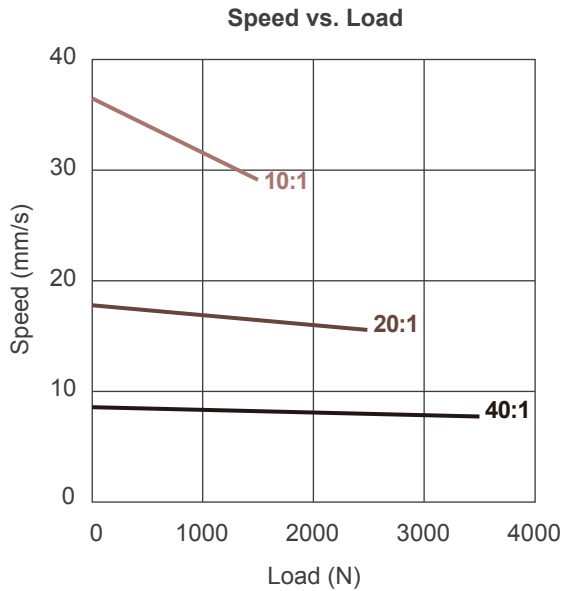

Ball Screw type

● 12V DC motor

Model No.	Gear ratio	Push/Pull Max. (N)	*Typical Speed (mm/s)		*Typical Current (A)	
			No load	Full load	No load	Full load
AID10-12-05-B-XXX	5:1	2500	67.1	47.2	3.4	26.4
AID10-12-10-B-XXX	10:1	3500	33.5	26.7	2.6	17.6
AID10-12-20-B-XXX	20:1	4500	16.8	14.3	2.6	13.2
AID10-12-30-B-XXX	30:1	6000	11.2	9.8	2.6	12.1
AID10-12-40-B-XXX	40:1	7000	8.4	7.4	2.6	11.0

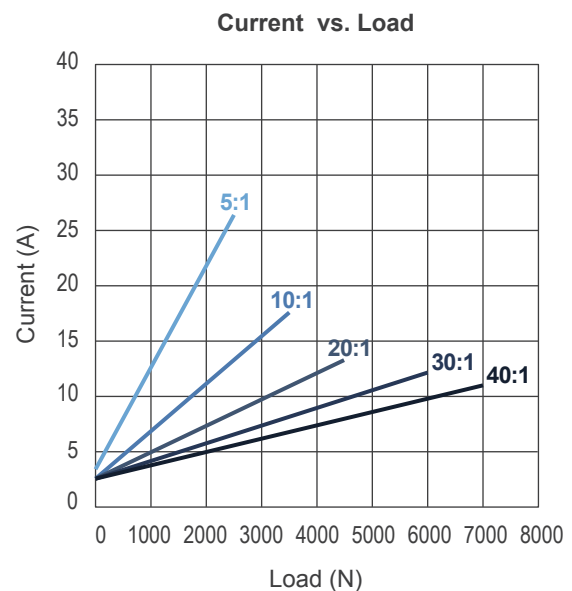
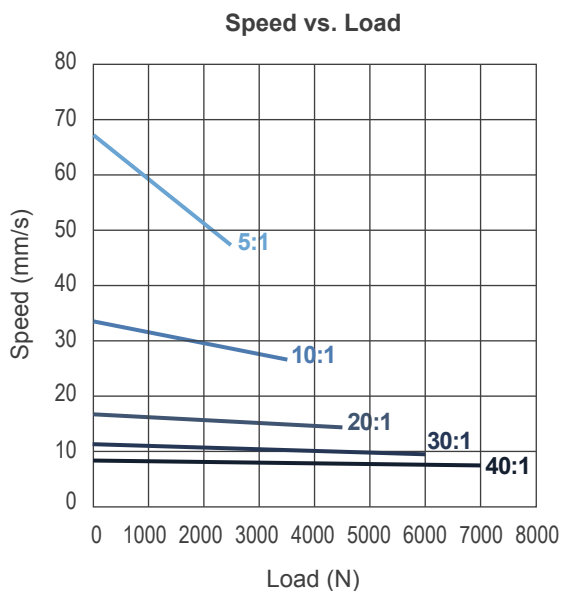

● 24V DC motor

Model No.	Gear ratio	Push/Pull Max. (N)	*Typical Speed (mm/s)		*Typical Current (A)	
			No load	Full load	No load	Full load
AID10-24-05-B-XXX	5:1	2500	67.1	47.2	2.6	13.2
AID10-24-10-B-XXX	10:1	3500	33.5	26.7	1.6	8.8
AID10-24-20-B-XXX	20:1	4500	16.8	14.3	1.6	6.6
AID10-24-30-B-XXX	30:1	6000	11.2	9.8	1.6	6.1
AID10-24-40-B-XXX	40:1	7000	8.4	7.4	1.6	5.5

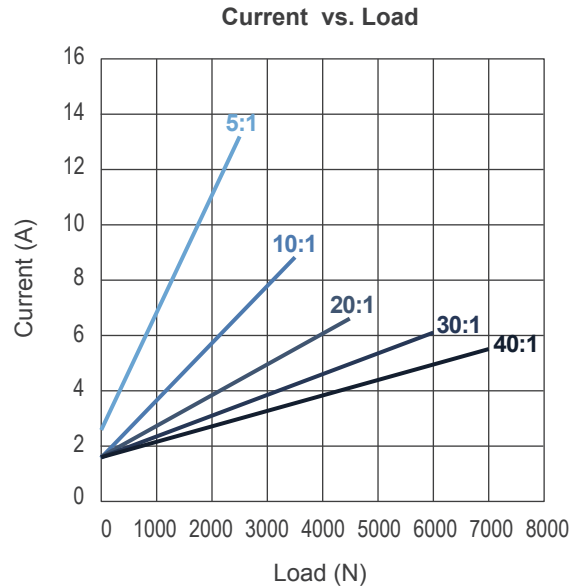
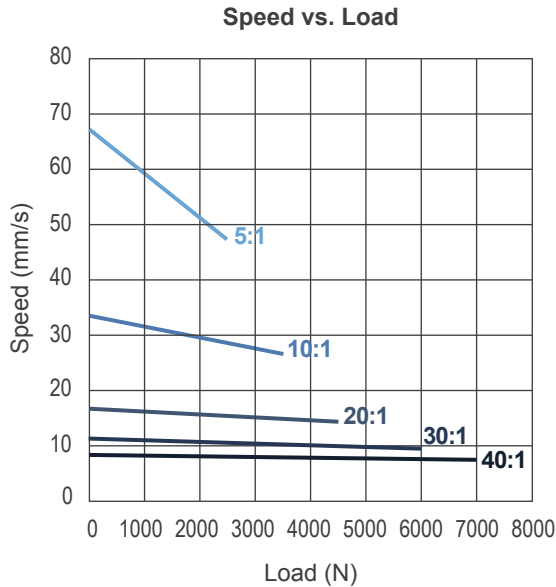

● 48V DC motor

Model No.	Gear ratio	Push/Pull Max. (N)	*Typical Speed (mm/s)		*Typical Current (A)	
			No load	Full load	No load	Full load
AID10-48-05-B-XXX	5:1	2500	72.1	57.5	0.5	5.5
AID10-48-10-B-XXX	10:1	3500	36.5	29.1	0.5	3.6
AID10-48-20-B-XXX	20:1	4500	17.8	15.3	0.5	2.4
AID10-48-30-B-XXX	30:1	6000	11.7	10.3	0.5	2.5
AID10-48-40-B-XXX	40:1	7000	8.6	7.8	0.5	2.1

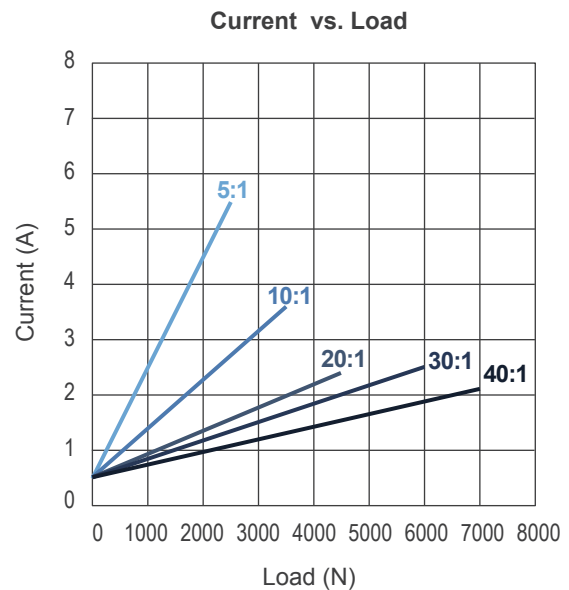
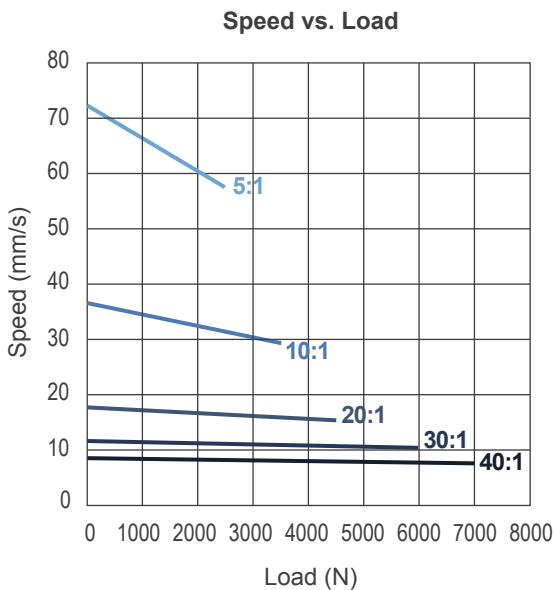

Remarks:

* The typical speed or typical current means the average value neither upper limit nor lower limit.
The performance curves are made with typical values.

Dimensions

ACME type

- Standard (without Limit switch nor Potentiometer)

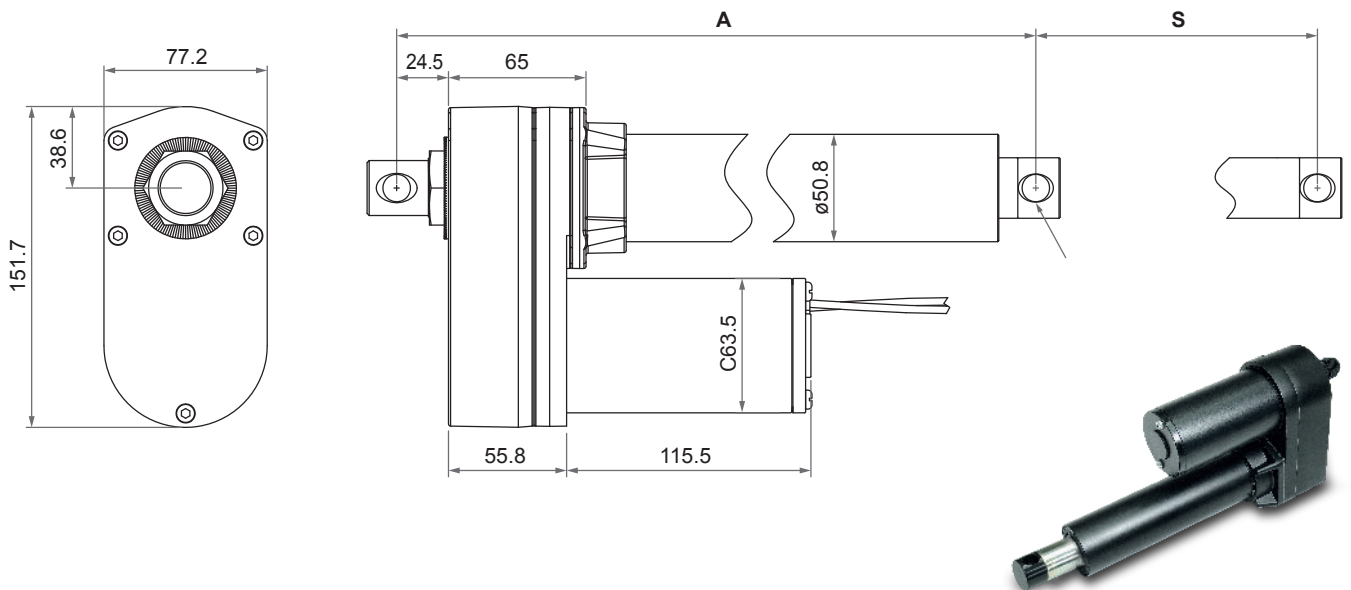

- With Limit switches (LT) or Potentiometer (POT)

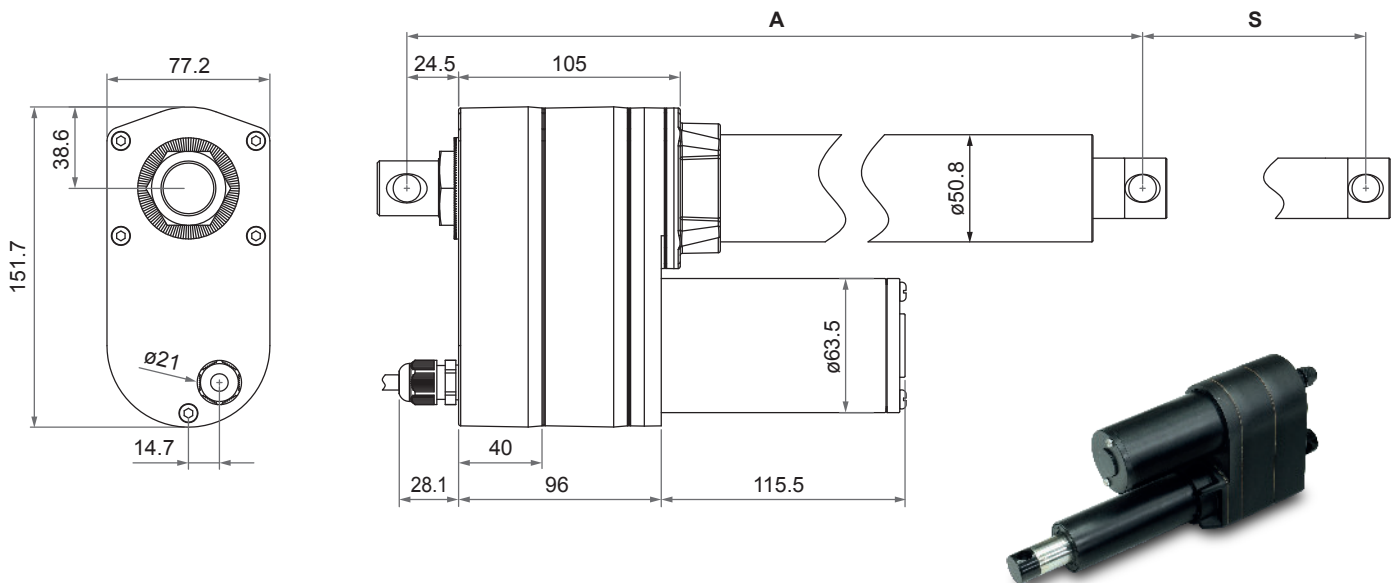

- Installation Dimension

Retracted length (A)

Option	Stroke (S)						
	102 (4")	153 (6")	203 (8")	254 (10")	305 (12")	457 (18")	610 (24")
Standard	262	313	364	414	465	668	821
*POT/LT	302	353	404	454	505	708	861

(tolerance: ± 5 mm)

*Hall effect sensor potentiometer

Ball Screw type

- Standard (without Limit switch nor Potentiometer)

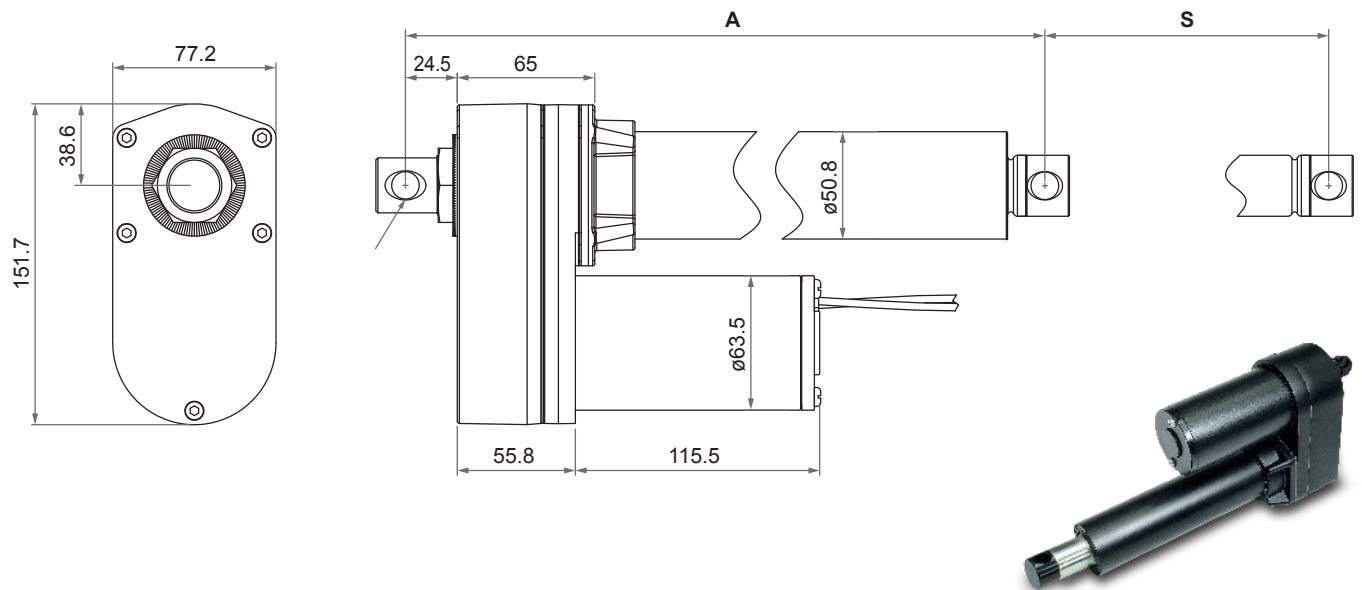

- With Limit switches (LT) or Potentiometer (POT)

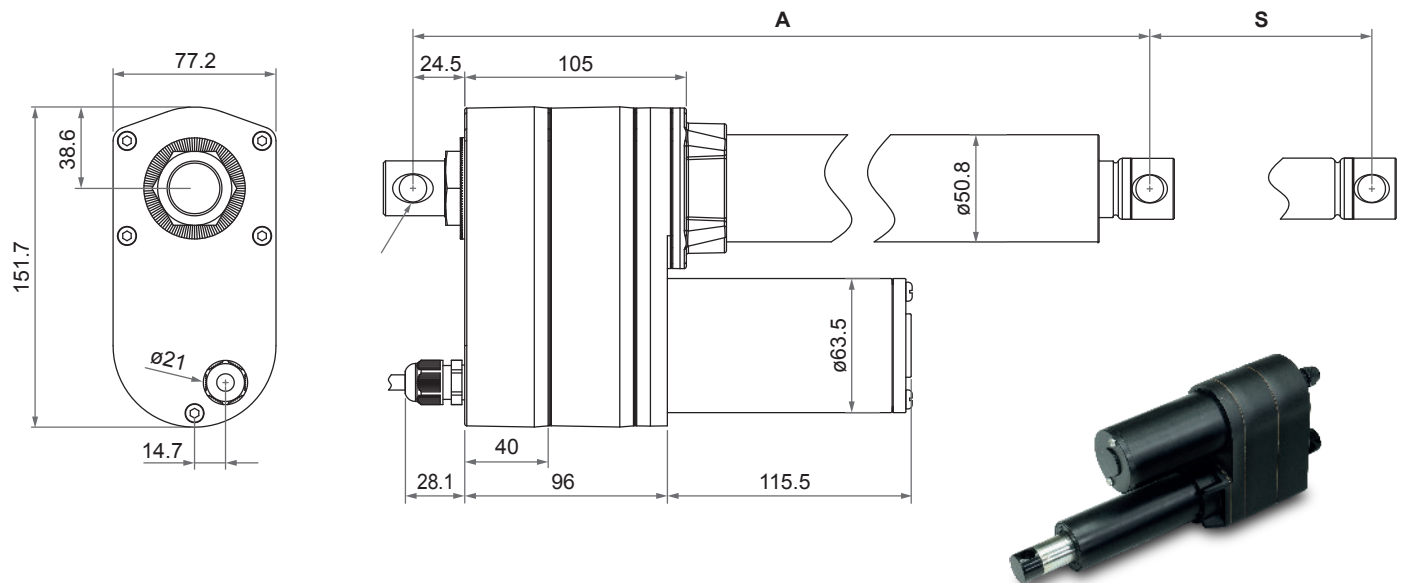

• Installation Dimension

Retracted length (A)

Option	Stroke (S)							
	102 (4")	153 (6")	203 (8")	254 (10")	305 (12")	406 (16")	457 (18")	610 (24")
Standard	302	353	404	455	506	647	735	888
*POT/LT	342	393	444	495	546	687	775	928

(tolerance: ± 5 mm)

*Hall effect sensor potentiometer

● **Front connector**

ACME type

- Standard (without Limit switch nor Potentiometer)

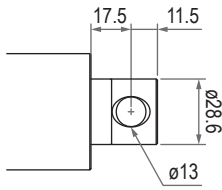

- With Limit switches (LT) or Potentiometer (POT)

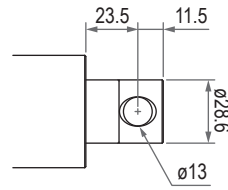

Ball Screw type

- Standard (without Limit switch nor Potentiometer)

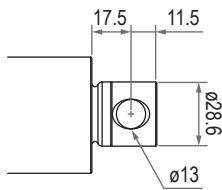

- With Limit switches (LT) or Potentiometer (POT)

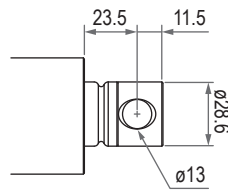

● **Rear connector**

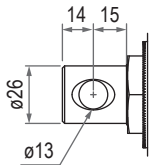

● **Pivot orientation of rear connector**

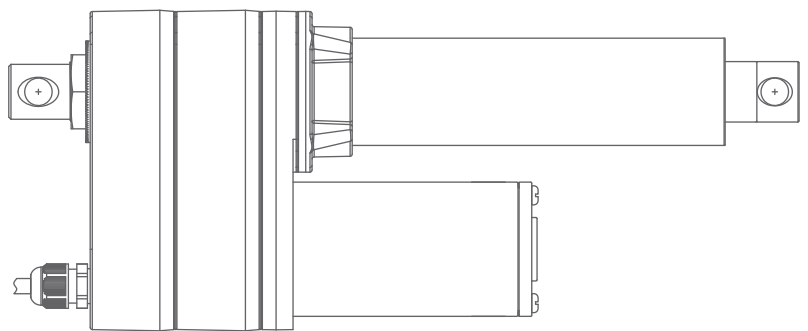
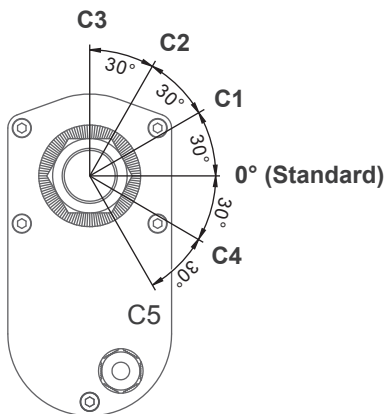

Note: As an example in 0° orientation.

● **Manual drive connector (MD)**

- Compatible with IP54 and Gear ratio 5:1、10:1 or 20:1
- Not applicable to IP65, Limit switches, nor Potentiometer options.
- Cable outlet from the motor.
- Please refer to "ID10 User Guide" for operation steps.

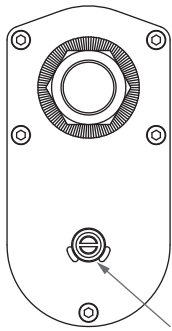

User needs 8mm hex bit screwdriver
(or electric screwdriver) to drive the motor.

● **Mounting bracket (MB30)**

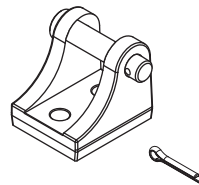
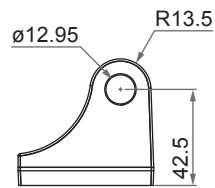
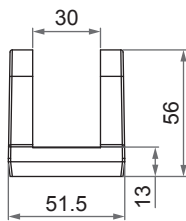
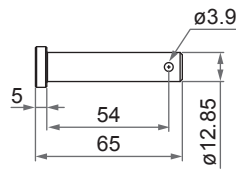
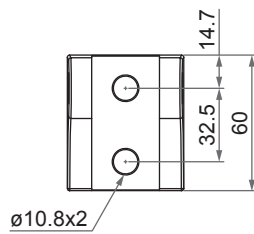

Compatibility

Product	Model	AID10 spec
Control box	CI10	<ul style="list-style-type: none"> - 24V motor - With limit switches option - Without positioning sensor feedback
	CIS1	<ul style="list-style-type: none"> - 2 Actuator synchronisation - 24V motor - With single Hall effect sensor for positioning
	CIS2	<ul style="list-style-type: none"> - 2 Actuator synchronisation - 12V motor - With single Hall effect sensor for positioning
	CIS3	<ul style="list-style-type: none"> - 2 Actuator synchronisation - 24V motor - With Potentiometer for positioning
Power limit control - adjustable	GS24-10MO	24 Vdc motor < 10 ampere
	GS24-5MO	24 Vdc motor < 5 ampere
	GS12-20MO	12 Vdc motor < 20 ampere
	GS12-10MO	12 Vdc motor < 10 ampere
	GS12-5MO	12 Vdc motor < 5 ampere

Wiring

Wire definitions:

• Without positioning sensor feedback

Gear ratio	Power	
	Red	Black
5:1, 10:1, 20:1	M+	M-
30:1, 40:1	M-	M+

Note:

1. Connect Red (M+) to '+' & Black (M-) to '-' of DC power, the actuator will extend.
2. Connect Red (M-) to '+' & Black (M+) to '-' of DC power, the actuator will extend.



• With limit switches

Power	
Red	Black
M+	M-

Note: Connect Red (M+) to '+' & Black (M-) to '-' of DC power, the actuator will extend.



• With Hall effect sensor x 1

Resolution, 20ppi, 1.27mm/pulse (0.787 pulses/mm)

Power		Signal		
Red	Black	White	Yellow	Blue
M+	M-	VCC	Data	GND

Note:

1. Connect Red (M+) to '+' & Black (M-) to '-' of DC power, the actuator will extend.
2. Voltage input range (VCC): 3.5~20V
3. Output voltage of signal (Data) = Input voltage of VCC
4. Hall signal data

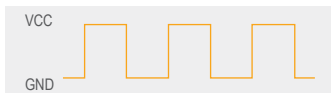

• With potentiometer (POT)

The resistance between blue and white wires increases when the actuator extends, and decreases when it retracts.

Power		Signal		
Red	Black	White	Yellow	Blue
M+	M-	GND	VCC	Data

Stroke (mm)	Resistance (tolerance: ±0.3KΩ)
102	0.3 ~ 8.1K
153	0.3 ~ 8.7K
203	0.3 ~ 9.2K
254	0.3 ~ 7.4K
305	0.3 ~ 8.8K
457	0.3 ~ 9.4K
610	0.3 ~ 9.8K

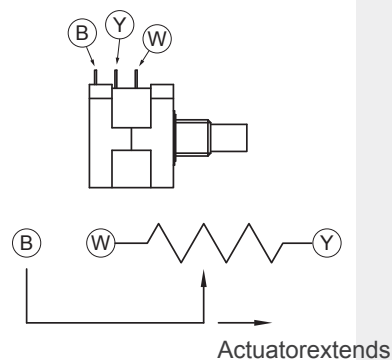

Note: Connect Red (M+) to '+' & Black (M-) to '-' of DC power, the actuator will extend.

Ordering Key

AID10 - 24 - 20 - A - 102 - POT - LT - M1

Input voltage	12: 12V DC 24: 24V DC 48: 48V DC
Gear ratio	05: 5:1 (Ball Screw only) 10: 10:1 20: 20:1 30: 30:1 (Ball Screw only) 40: 40:1
Spindle type	A: ACME B: Ball Screw
Stroke	102: 102 mm (4") 153: 153 mm (6") 203: 203 mm (8") 254: 254 mm (10") 305: 305 mm (12") 406: 406 mm (16") 457: 457 mm (18") 610: 610 mm (24")
Positioning feedback (alternative)	POT: Potentiometer (Including LT) HS: Hall effect sensor x 1 (Including LT)
Option (multiple choice is allowed)	LT: Limit switches IP65: IP65 protection level MD: Manual drive connector (Refer to page 8 for conditions to order) TP: Thermal protection (Not compatible with 12V DC / gear ratio 5:1)
Pivot orientation of Rear connector	Blank: 0° (Standard) C1: 30° counter-clockwise C2: 60° counter-clockwise C3: 90° counter-clockwise C4: 30° clockwise C5: 60° clockwise (Please refer to page 8)
Mounting bracket (MB30)	Blank: None M1: Mounting bracket x 1 M2: Mounting bracket x 2 (Please refer to page 9)

Certifications

The AID10 actuator is compliant with the following regulations, in terms of the essential conformity requirements of EMC Directive of 2014/30/EU.

Emission	Immunity
EN 61000-6-3:2007+A1:2011	EN 61000-6-1:2007 IEC 61000-4-2:2008 IEC 61000-4-3:2006+A1:2007+A2:2100 IEC 61000-4-8:2009

Tel: +31 (0)85 0668800
Mail: verkoop@aamotionandcontrol.nl
www.aamotionandcontrol.nl



Terms of Use

The user is responsible for application suitability of A&A Motion and Control products. As ongoing improvement process continues, products listed on the A&A Motion and Control website are subject to change without prior notice. Moteck reserves the right to terminate the sales or remove any product displayed on the website, or listed in its catalogues.