

# Actuator

## AID10-230/400 Vac

AID10 features its heavy load capability and high speed design, which is suitable for various industrial applications requiring quick movement, such as agricultural and construction machine. Ball Screw or ACME spindle is available for users to choose.

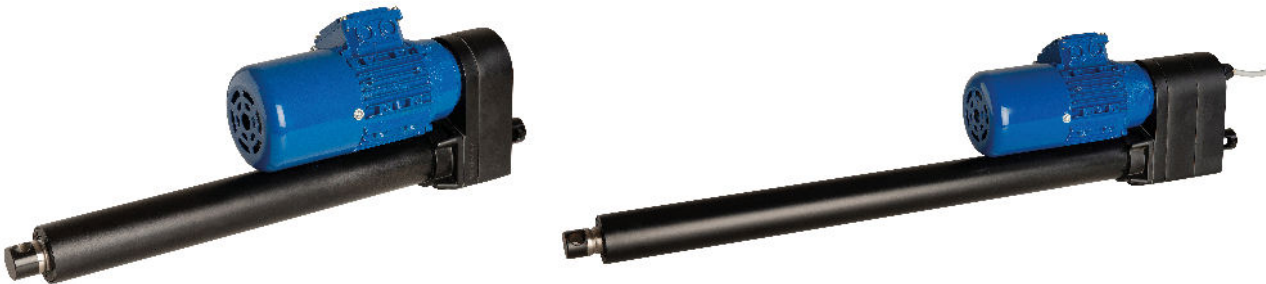

### Feature

---

- Main applications: Industrial
- Input voltage: 230/400 Vac motor with electromechanic brake
- Max. rated load: 3,500N (ACME) / 7,000N (Ball Screw)
- Max. static load: 4,500N (ACME) / 13,600N (Ball Screw)
- Typical speed at no load: 56 mm/sec
- Stroke: 102 ~ 610 mm
- IP Protection level: IP54
- Overload protection by clutch
- Extension tube material: Iron (ACME) or stainless steel (Ball Screw)
- Color: Black/blue
- Duty cycle 100%
- Ambient operation temperature: -25°C ~ +65°C
- Certified: CE Marking, EMC Directive 2014/30/EU

## Option

- Positioning signal feedback with Hall effect sensor x 1
- Analog and absolute positioning feedback with Potentiometer (POT)
- Preset limit switches (LT), as signal to stop motor automatically at both stroke ends by cutting power.
- IP Protection level: IP65
- Mounting bracket (MB30) (*Fig. 1*)

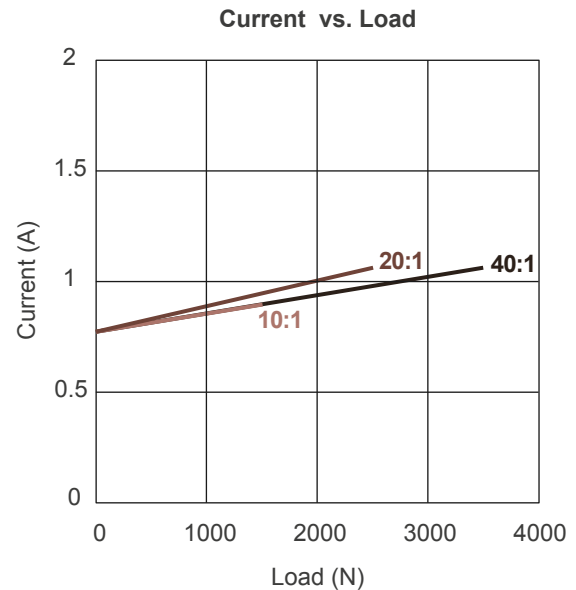
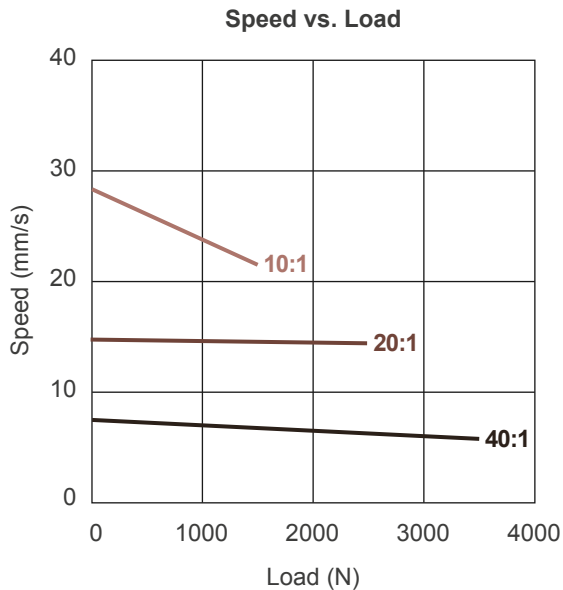

Fig. 1

## Performance Data

### ACME type

Model No.	Gear ratio	Push/Pull Max. (N)	*Typical Speed (mm/s)		*Typical Current (A)	
			No load	Full load	No load	Full load
AID10-12-10-A-XXX	10:1	1500	29	23	0.75	1.1
AID10-12-20-A-XXX	20:1	2500	15	13	0.75	1.0
AID10-12-40-A-XXX	40:1	3500	8	6,5	0.75	0.9



### Ball Screw type

Model No.	Gear ratio	Push/Pull Max. (N)	*Typical Speed (mm/s)		*Typical Current (A) 400 vac	
			No load	Full load	No load	Full load
AID10-12-05-B-XXX	5:1	2500	56	43	0,8	1,2
AID10-12-10-B-XXX	10:1	3500	30	25	0,8	1,1
AID10-12-20-B-XXX	20:1	4500	15	13	0,8	1,1
AID10-12-30-B-XXX	30:1	6000	10	8,5	0,7	0,9
AID10-12-40-B-XXX	40:1	7000	8	7	0,7	0,9

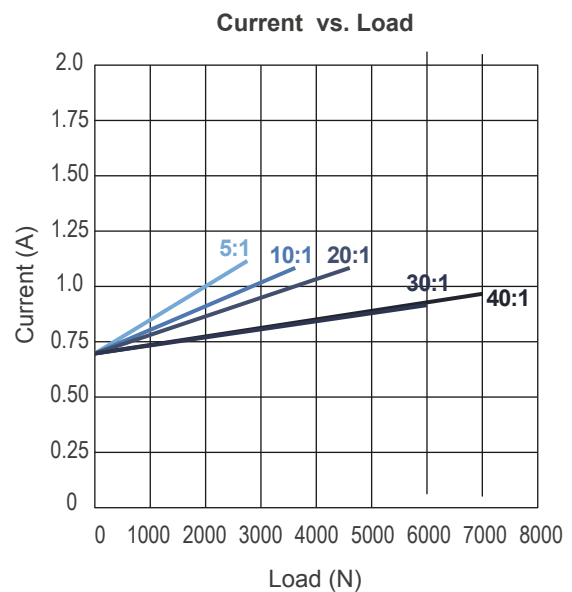
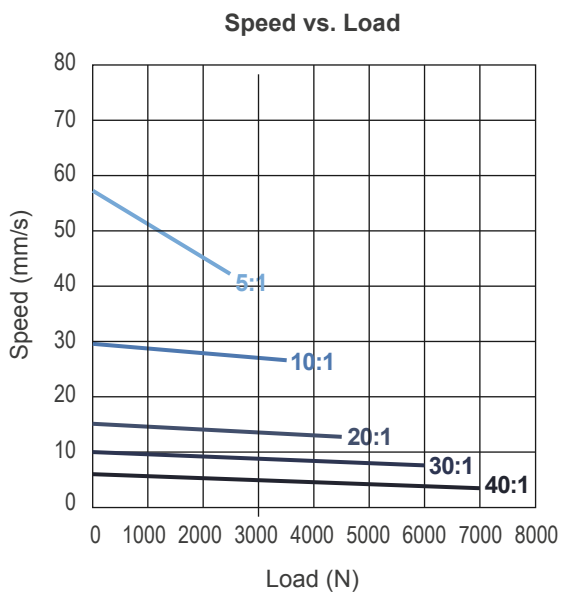

## Dimensions

### ACME type

- Standard (without Limit switch nor Potentiometer)

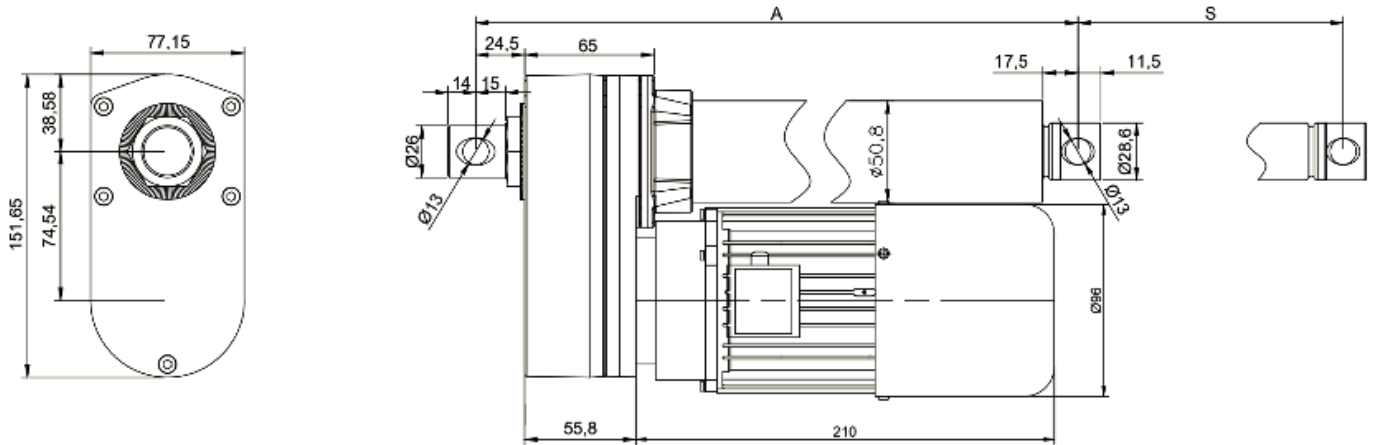

- With Limit switches (LT) or Potentiometer (POT)

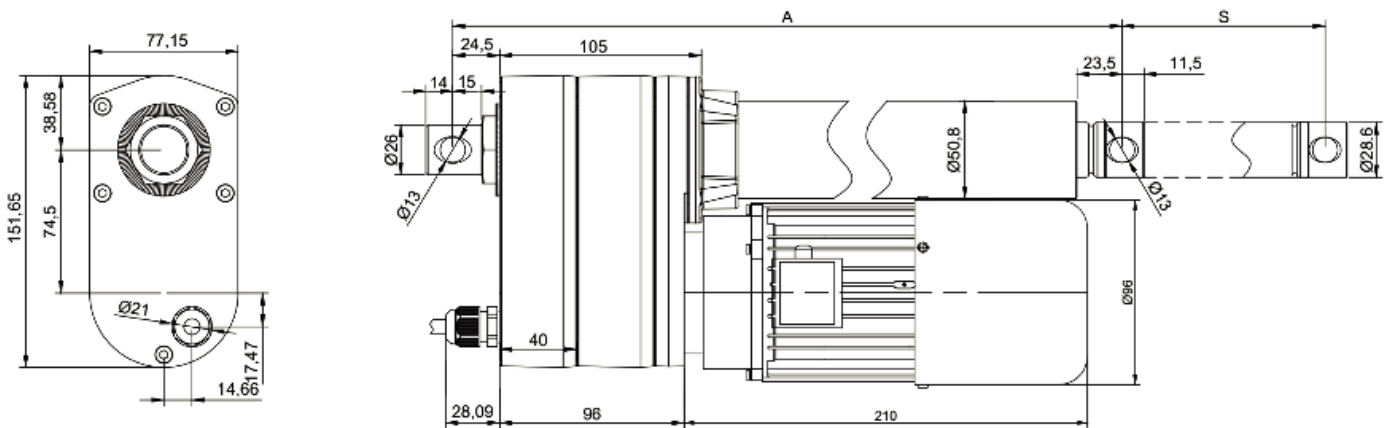

- Installation Dimension

#### Retracted length (A)

Option	Stroke (S)						
	102 (4")	153 (6")	203 (8")	254 (10")	305 (12")	457 (18")	610 (24")
Standard	262	313	364	414	465	668	821
*POT/LT	302	353	404	454	505	708	861

(tolerance:  $\pm 5$ mm)

\*Hall effect sensor potentiometer & switch

## Ball Screw type

- Standard (without Limit switch nor Potentiometer)

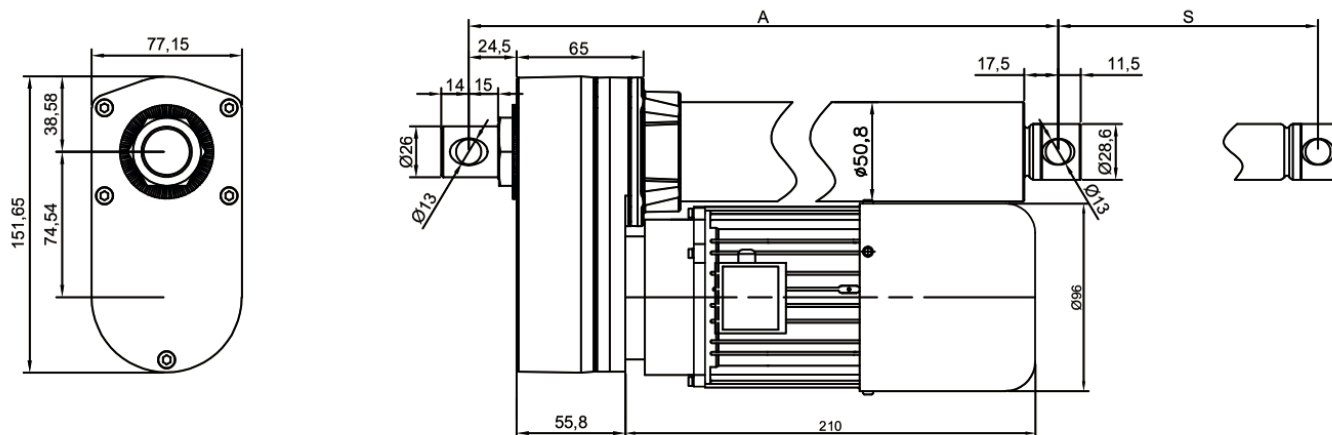

- With Limit switches (LT) or Potentiometer (POT)

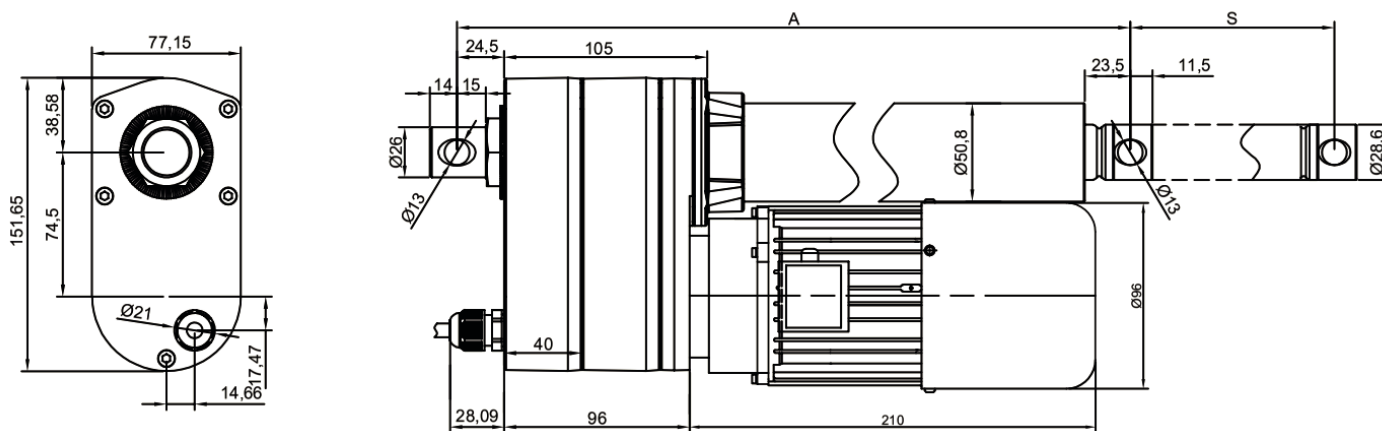

- Installation Dimension

### Retracted length (A)

Option	Stroke (S)							
	102 (4")	153 (6")	203 (8")	254 (10")	305 (12")	406 (16")	457 (18")	610 (24")
Standard	302	353	404	455	506	647	735	888
*POT/LT	342	393	444	495	546	687	775	928

(tolerance: ±5mm)

\*Hall effect sensor potentiometer & switch

● **Front connector**

**ACME type**

- Standard (without Limit switch nor Potentiometer)

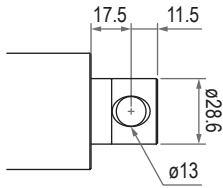

- With Limit switches (LT) or Potentiometer (POT)

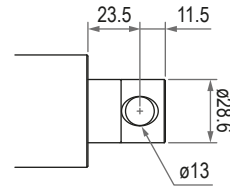

**Ball Screw type**

- Standard (without Limit switch nor Potentiometer)

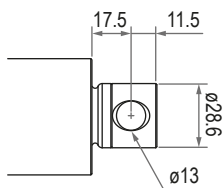

- With Limit switches (LT) or Potentiometer (POT)

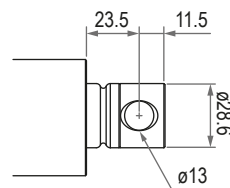

● **Rear connector**

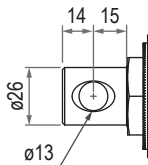

● **Pivot orientation of rear connector**

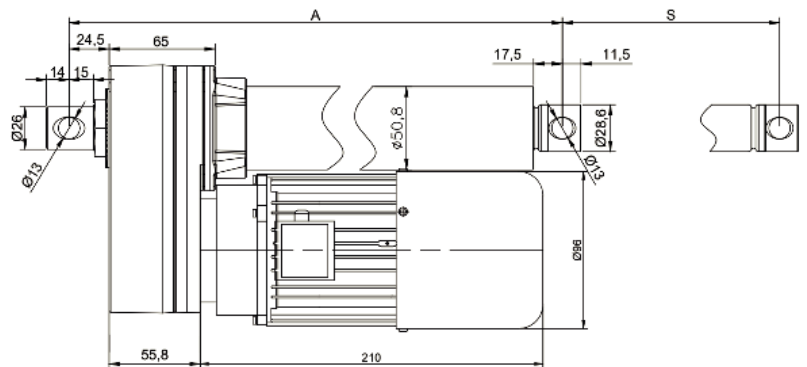
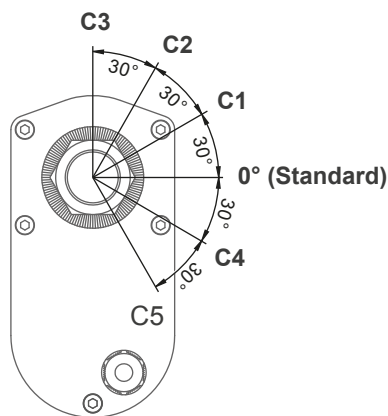

**Note:** As an example in 0° orientation.

• Mounting bracket (MB30)

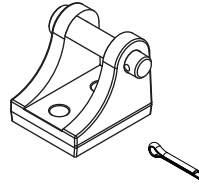
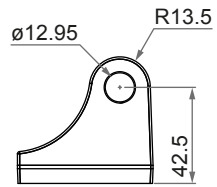
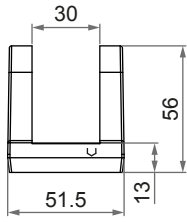
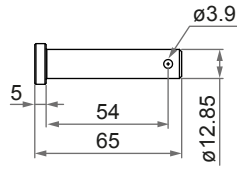
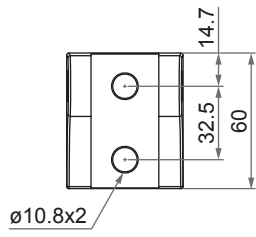

# Wiring

## Wire and connection definitions:

The motor is delivered in Y- configuration to a 3 fase 400Vac. 50Hz powerline.

Y-connection

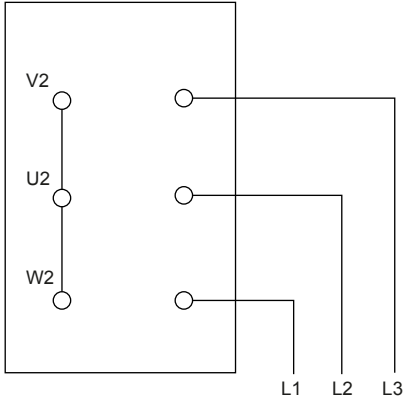

Caution: in case of separate control of the integrated brake, brake will operate on 230 Vac. 50 Hz only.

### • With Hall effect sensor x 1

Resolution, 20ppi, 1.27mm/pulse (0.787 pulses/mm)

Signal		
White	Yellow	Blue
VCC	Data	GND

#### Note:

1. Connect Red (M+) to '+' & Black (M-) to '-' of DC power, the actuator will extend.
2. Voltage input range (VCC): 3.5~20V
3. Output voltage of signal (Data) = Input voltage of VCC
4. Hall signal data



### • With potentiometer (POT)

The resistance between blue and white wires increases when the actuator extends, and decreases when it retracts.

Signal		
White	Yellow	Blue
GND	VCC	Data

Stroke (mm)	Resistance (tolerance: $\pm 0.3K\Omega$ )
102	0.3 ~ 8.1K
153	0.3 ~ 8.7K
203	0.3 ~ 9.2K
254	0.3 ~ 7.4K
305	0.3 ~ 8.8K
457	0.3 ~ 9.4K
610	0.3 ~ 9.8K

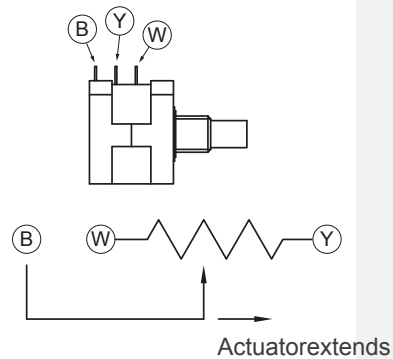

Note: Connect Red (M+) to '+' & Black (M-) to '-' of DC power, the actuator will extend.



## Ordering Key

**AID10 - 230/400 - 20 - A - 102 - POT - LT - M1**

<b>Input voltage</b>	<b>230/400</b>
<b>Gear ratio</b>	<b>05:</b> 5:1 (Ball Screw only) <b>10:</b> 10:1 <b>20:</b> 20:1 <b>30:</b> 30:1 (Ball Screw only) <b>40:</b> 40:1
<b>Spindle type</b>	<b>A:</b> ACME <b>B:</b> Ball Screw
<b>Stroke</b>	<b>102:</b> 102 mm (4") <b>153:</b> 153 mm (6") <b>203:</b> 203 mm (8") <b>254:</b> 254 mm (10") <b>305:</b> 305 mm (12") <b>406:</b> 406 mm (16") <b>457:</b> 457 mm (18") <b>610:</b> 610 mm (24")
<b>Positioning feedback (alternative)</b>	<b>BLANK:</b> NONE <b>POT:</b> Potentiometer (Including LT) <b>HS:</b> Hall effect sensor x 1 (Including LT)
<b>Option (multiple choice is allowed)</b>	<b>BLANK:</b> NONE <b>LT:</b> Limit switches
<b>Pivot orientation of Rear connector</b>	<b>Blank:</b> 0° (Standard) <b>C1:</b> 30° counter-clockwise <b>C2:</b> 60° counter-clockwise <b>C3:</b> 90° counter-clockwise <b>C4:</b> 30° clockwise <b>C5:</b> 60° clockwise (Please refer to page 8)
<b>Mounting bracket (MB30)</b>	<b>Blank:</b> None <b>M1:</b> Mounting bracket x 1 <b>M2:</b> Mounting bracket x 2

## Certifications

The AID10 actuator is compliant with the following regulations, in terms of the essential conformity requirements of EMC Directive of 2014/30/EU.

Emission	Immunity
EN 61000-6-3:2007+A1:2011	EN 61000-6-1:2007 IEC 61000-4-2:2008 IEC 61000-4-3:2006+A1:2007+A2:2100 IEC 61000-4-8:2009

Tel: +31 (0)85 0668800  
Mail: [verkoop@aamotionandcontrol.nl](mailto:verkoop@aamotionandcontrol.nl)  
[www.aamotionandcontrol.nl](http://www.aamotionandcontrol.nl)



### Terms of Use

The user is responsible for application suitability of A&A Motion and Control products. As ongoing improvement process continues, products listed on the A&A Motion and Control website are subject to change without prior notice. Moteck reserves the right to terminate the sales or remove any product displayed on the website, or listed in its catalogues.