

# Controller ACI72

ACI72 is a multi-functional and multi-purpose industrial control board that supports 2 industrial actuators for synchronously applications. ACI72 can be select set to switch control mode or servo control, by the user through DIP switches, or other adjustable parameters.



## Features

---

- Main applications: Industrial, Agriculture, Construction
- Input voltage: 12 / 24V DC
- Number of actuators to control: max. 2 (synchronous move)
- Max. current limit: 25A (each actuator)
- Use the DIP switch to set the following function parameters
  - Select switch control or servo control mode
  - Select single actuator or 2 actuators
  - Support POT or Hall sensor (NPN type only) positioning feedback
  - Four-levels adjustable soft start / stop slope
- 2.5A ~ 25A ten-levels adjustable over-current protection setting (2 actuators are the same)
- Duty cycle:
  - 2 x 25A at 15% duty cycle, max. 1 min. continuous operation in 6.5 min.
  - 2 x 20A at 25% duty cycle, max. 1 min. continuous operation in 4 min.
- Operating ambient temperature: -20°C ~ +55°C
- Option: DIN rail can be attached (assembly on standard NS 35 or NS 32 DIN rails)

# Dimensions

PCBA only

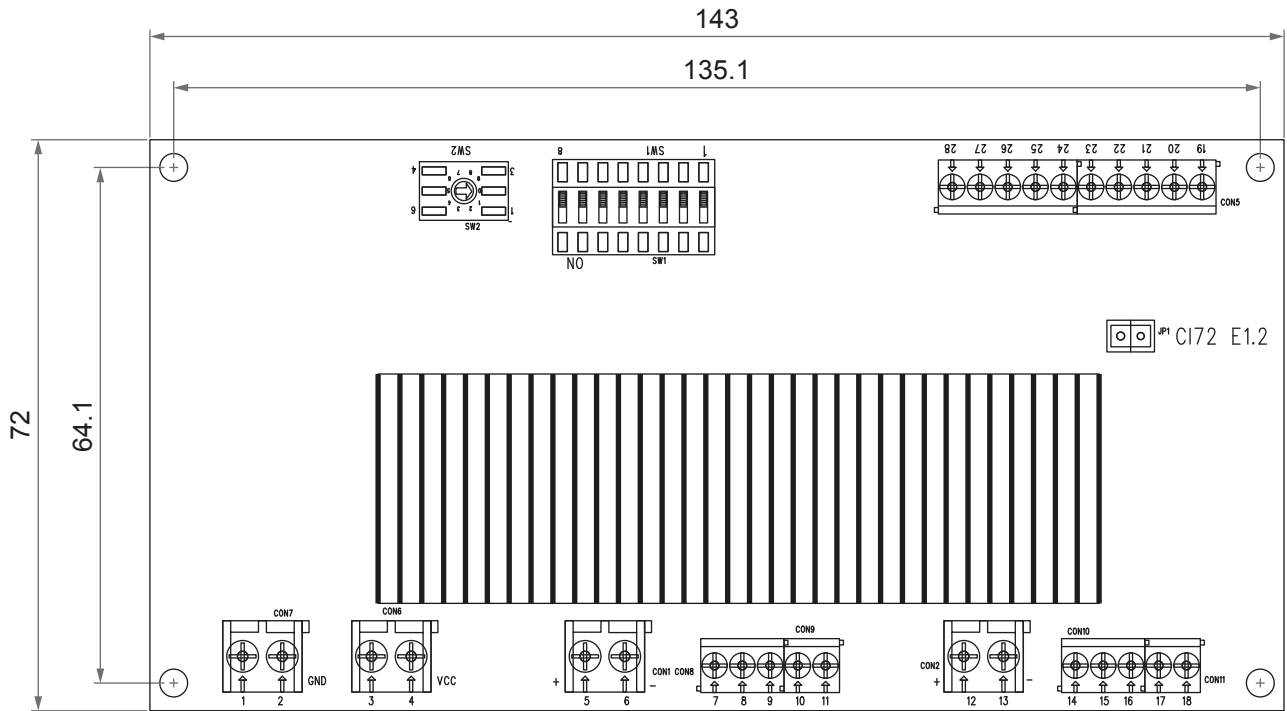

Unit: mm

Interface guide for PCBA Version E1.2

## 1. Switches and terminals

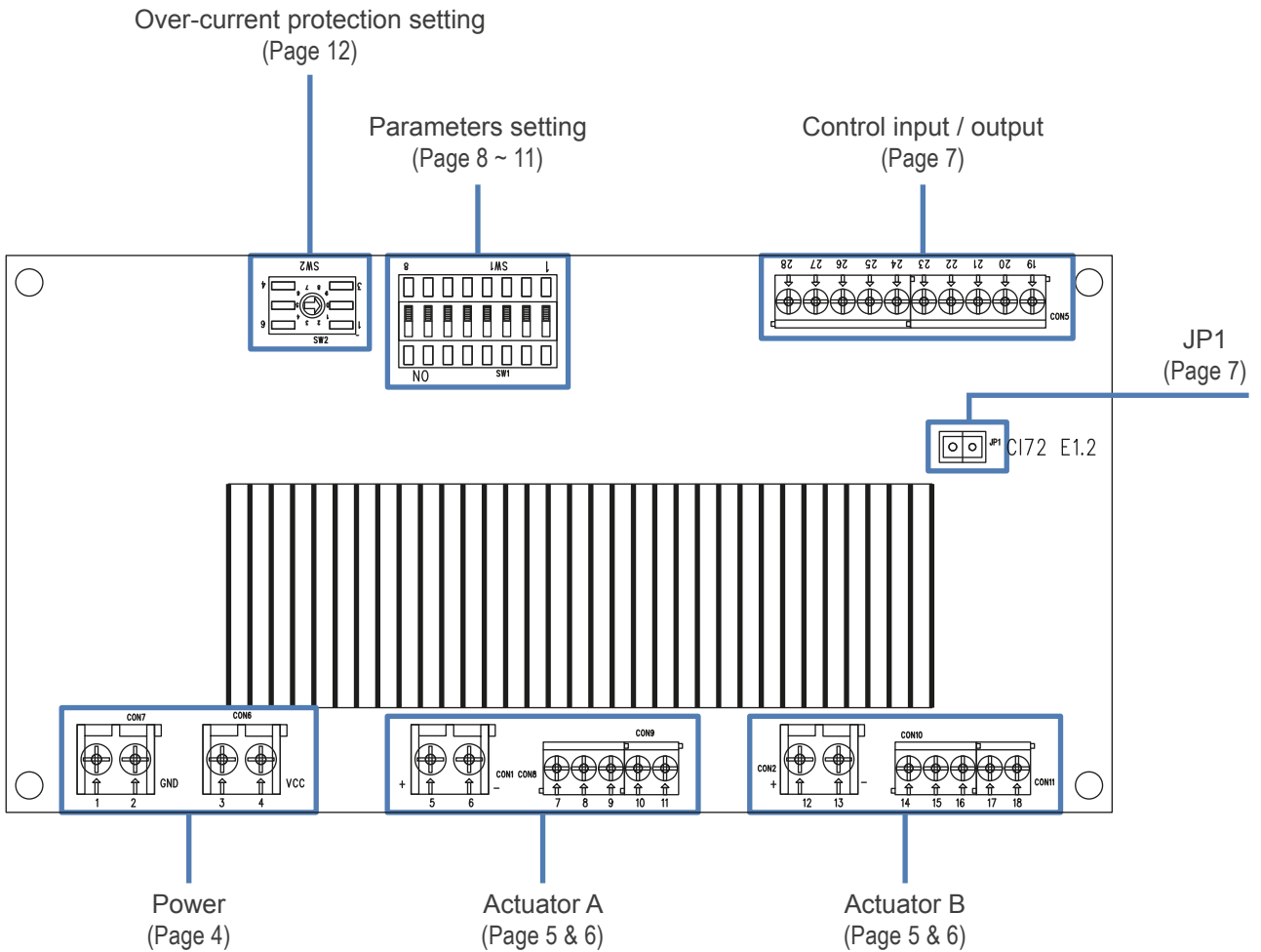

## 2. Power input

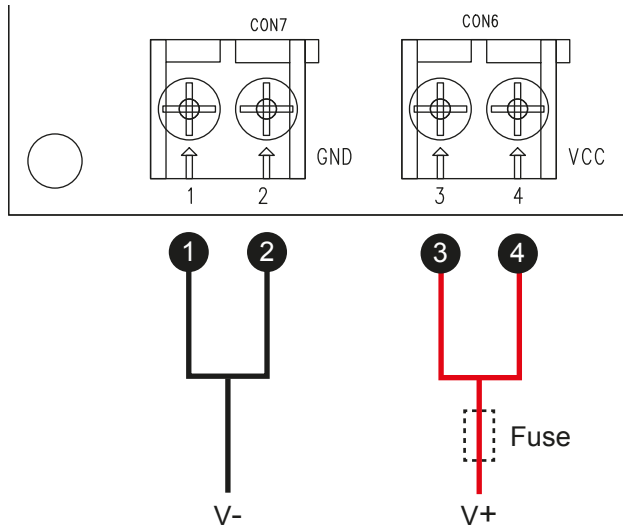

Port	Definition	Description
1	V-	GND each terminal allows the maximum conductor cross-section 3.3mm <sup>2</sup> (12AWG)
2		
3	V+	12 / 24V DC each terminal allows the maximum conductor cross-section 3.3mm <sup>2</sup> (12AWG)
4		

### Remarks:

- (1) Install a slow-blow fuse of between ACI72 and the power supply for protection.  
The fuse is connected by the customer. The recommended specification is 50A Max.
- (2) In order to avoid malfunctions caused by voltage drop, the cross-section of the power cord must be large enough, and the wire length from the power supply to the control board and from the control board to the actuator motor is as short as possible, and it is recommended not to exceed 1 meter. If the total load current is less than 30A, a single wire with a cross-sectional of 3.3mm<sup>2</sup> (12AWG) can be used. If the total load current is as high as 30A ~ 50A, it is recommended to use two wires with a cross-sectional of 2.0mm<sup>2</sup> (14AWG) or more in parallel.



- When the actuator starts, an inrush current will be generated for about 0.2 seconds, the starting inrush current of actuator is as high as 3 times the typical current of the actuator's maximum load.
- If a power supply is used, then the specification must be sufficient to withstand the inrush current of the customer using the maximum load. And if batteries are used as the power source, the surge current will not be a problem. Besides, customer's system uses connectors, switches and relays, the specifications must also be appropriate to withstand the inrush current.

### 3. Actuators terminals

- With Hall effect sensor

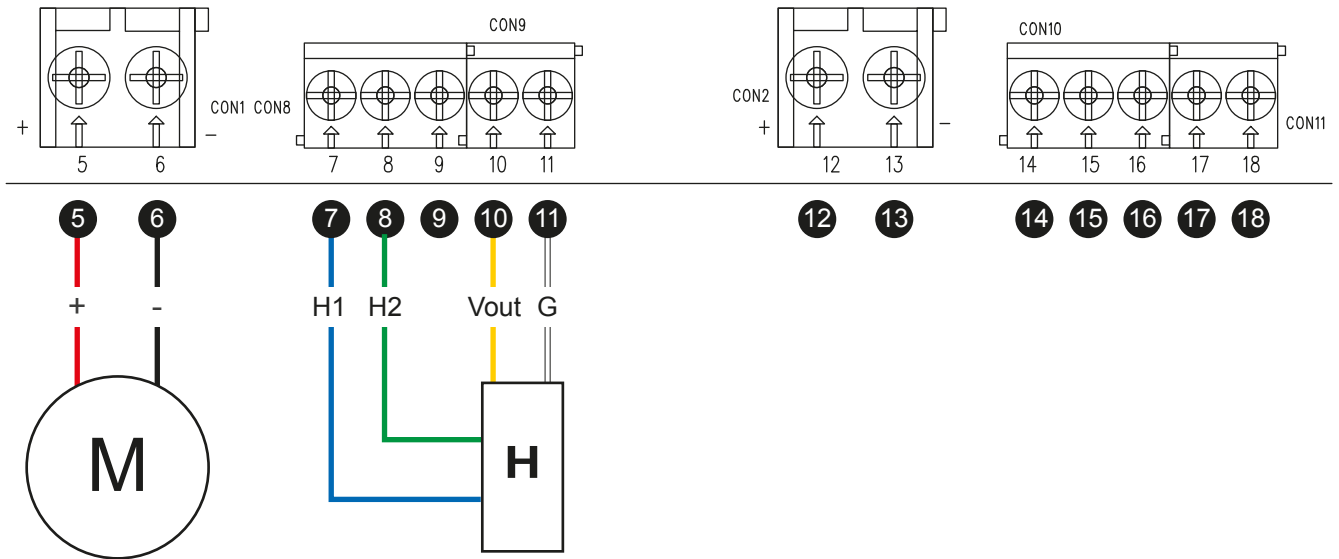

Port		Definition	Description
5	12	M+	12V or 24V DC output. When controlling the actuator to extend, M+ / M- are VDC+ / VDC- respectively. When retracting the actuator, the polarity is reversed.
6	13	M-	
7	14	H1	Hall Data 1 input
8	15	H2	
10	17	Vout	5V power supply for Hall
11	18	G	GND

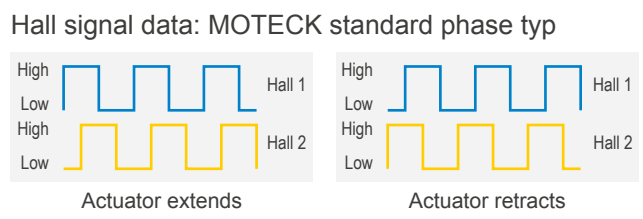

• With Potentiometer

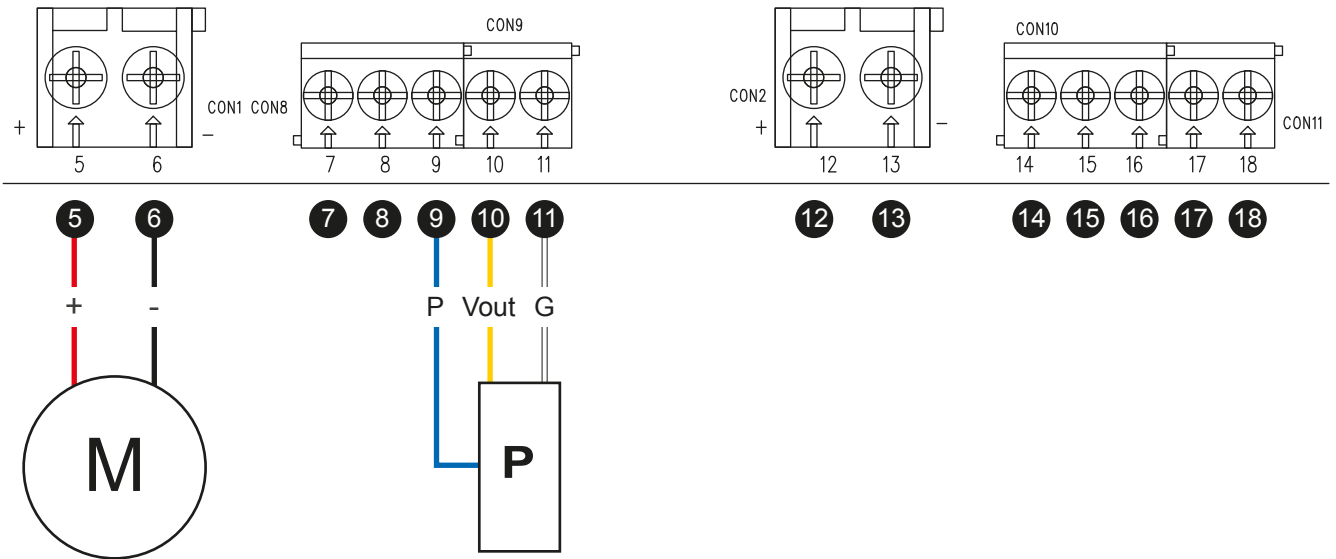

Port		Definition	Description
5	12	M+	12V or 24V DC output. When controlling the actuator to extend, M+ / M- are VDC+ / VDC- respectively. When retracting the actuator, the polarity is reversed.
6	13	M-	
9	16	P	POT signal input <div style="border: 1px solid black; padding: 5px; width: fit-content; margin: 5px auto;"> <p>Wiring:</p> </div>
10	17	Vout	5V power supply for POT
11	18	G	GND

## 4. Control input / output

\* The wiring prepared by the customer

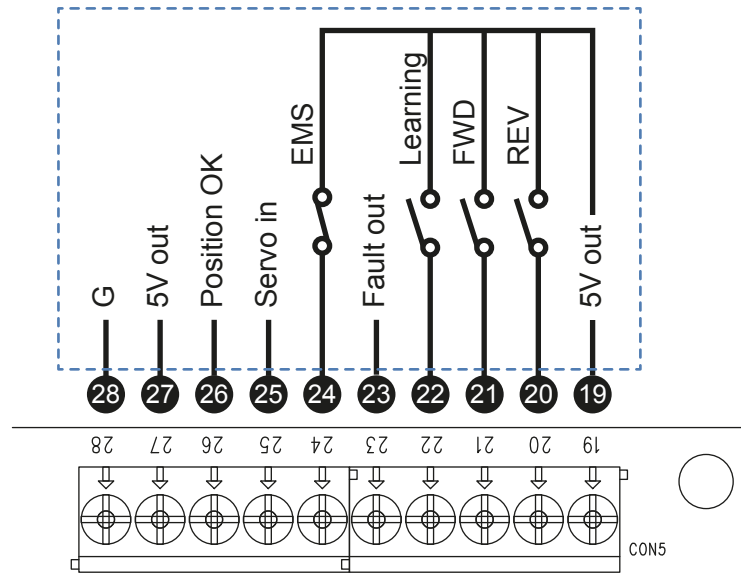

Port	Definition	Description
19	5V out	<ul style="list-style-type: none"> <li>5V power supply to the switch</li> </ul>
20	REV	<ul style="list-style-type: none"> <li>Switch signal input can use 5V of terminal 19 or external 5V power supply</li> <li>Actuator retracts when turn on</li> </ul>
21	FWD	<ul style="list-style-type: none"> <li>Switch signal input can use 5V of terminal 19 or external 5V power supply</li> <li>Actuator extends when turn on</li> </ul>
22	Learning	<ul style="list-style-type: none"> <li>Switch signal input can use 5V of terminal 19 or external 5V power supply, triggered after being turn on for &gt;0.5 seconds, the system will automatically learn the stroke of the actuators                      (actuator at any travel position → retract to the lower limit of the mechanism                      extend to the upper limit of the mechanism →                      retract to selected software limit position)</li> </ul>
23	Fault out	<ul style="list-style-type: none"> <li>Error signal output</li> <li>Output signal (5V) when over current or actuator no signal</li> </ul>
24	EMS	<ul style="list-style-type: none"> <li>Switch signal input (N.C.) must be connected to 5V power supply of terminal 19</li> <li>For customer to install emergency stop switch between terminals 19 and 24</li> <li>To use this function, the jumper of JP1 must be removed.</li> </ul>
25	Servo in	<ul style="list-style-type: none"> <li>Input (0 ~ 5V) specify the actuator to run to the specified location (0 ~ 5V evenly distributed to retracted to extended position of software limit)</li> <li>Can use external power signal or use 5V of terminal 27 to generate signal through variable resistance.</li> </ul>
26	Position OK	<ul style="list-style-type: none"> <li>In-position signal output</li> <li>When using the servo control mode, the actuator will output a signal (5V) after reaching the specified position (according to terminal 26).</li> </ul>
27	5V out	<ul style="list-style-type: none"> <li>5V power supply to the servo circuit</li> </ul>
28	G	<ul style="list-style-type: none"> <li>GND when using external servo signal, the power GND must be connected here.</li> </ul>



## Parameter Setting





- For safety, re-learning after each parameter adjustment.
- Please confirm the actuator specification before adjustment, and follow the setting instructions below.

### 1. Basic setting





#### 1.1 Control input mode

Parameters	Value	DIP switch
Switch control	0	
Servo control (0V ~ 5V DC)	1	

#### 1.2 Number of actuators to control

Parameters	Value	DIP switch
Actuator x2	0	
Actuator x1	1	

### 1.3 Types of actuator positioning

Parameters	Value	DIP switch
With dual Hall effect sensors	00	
With single Hall effect sensor	01	
With potentiometer (POT)	10	
Without positioning sensor	11	



1. If the selected control input mode is "servo control" (see 1.1), the actuator must be equipped with positioning feedback function (Hall sensors or potentiometer).
2. If the actuators have no positioning sensor, they must have limit switches that can cut off the power and stop by themselves, otherwise there is a high risk of damage to ACI72.
3. If 2 actuators are selected and there is no positioning sensor, the control board only provides simultaneous motion without synchronization.

## 2. Other parameter settings



- When setting up for the first time, install and fix the actuators properly, and then set the CI72.
- At the beginning, it is recommended to set the software stroke limit and soft start / stop parameters to 00 respectively.

### 2.1 Software stroke limit setting

Parameters		Value	DIP switch
With Hall effect sensor	With potentiometer		
Set the limit position at 40 pulses before the two ends.	Set the limit position at 2% of the full stroke before both ends.	00	
Set the limit position at 20 pulses before the two ends.	Set the limit position at 1% of the full stroke before both ends.	01	
Set the limit position at 10 pulses before the two ends.	Set the limit position at 0.5% of the full stroke before both ends.	10	
No software limit (only selectable under the actuator with physical limit switches).	No software limit (only selectable under the actuator with physical limit switch).	11	

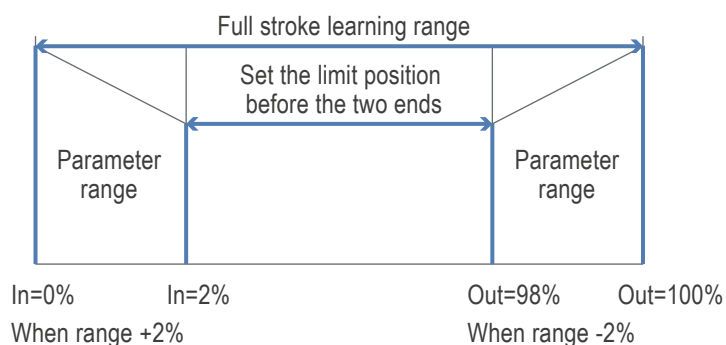





**Schematic diagram of software limit setting**  
(take the actuator with potentiometer as an example)

- \* Please refer to the actuator Data Sheet for the relationship between the number of Hall sensor pulses and the stroke.

## 2.2 Soft start/stop ramp setting

- This parameter is used to set the time of soft start (and soft stop) to adjust the speed change slope.
- After turning on this function, it will show soft start when starting at any position within the full stroke range.
- After selecting the servo control mode and turning on this function, it will slowly stop at any position within the full stroke range.
- However, if the switch control mode is selected, the soft stop function is only valid before both ends of the stroke, and there is no soft stop in the middle.

Parameters	Value	DIP switch
0 second	00	
0.5 seconds	01	
1.0 seconds	10	
1.5 seconds	11	

### 2.3 Over-current protection setting

(please refer to the full load current in the Data Sheet of the actuators +20%)

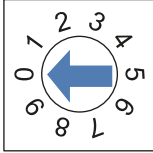
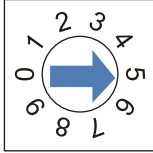
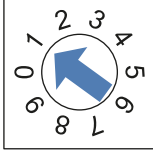
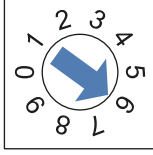
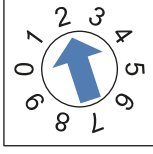
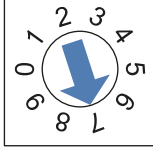
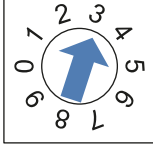
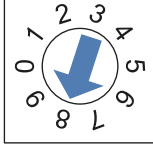
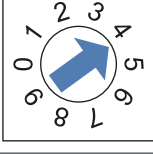
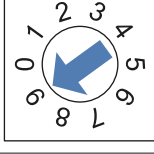
Parameters	Value	Rotary switch	Parameters	Value	Rotary switch
2.0A	0		10.0A	5	
3.0A	1		12.5A	6	
4.0A	2		15.0A	7	
6.0A	3		20.0A	8	
8.0A	4		25.0A	9	

## 2.4 Learning for actuators stroke



- The learning mode must be carried out under no load.
- If the actuator has no positioning sensor, there is no need to learn. Please test run directly (see 2.5).

- Step 1. After the setting is completed, turn on terminal ②② (learning) for more than 0.5 seconds to trigger, and the system will automatically learn the actuator stroke.
- Step 2. After learning, please check the retracted end position of the actuator, and adjust the software limit parameters according to the situation (see 2.1).
- Step 3. Re-learn after adjusting the parameters, try different parameters to tune out the best effective stroke.

## 2.5 Test run

- Step 1. Test running the full stroke
- Step 2. Set soft start/stop parameter according to requirements (see 2.2).
- Step 3. Test run after adding appropriate load to confirm the best parameter settings.

## Compatibility

### Actuator compatibility requirements

- 12V DC or 24V DC motor, and the speed can be adjusted by PWM power supply.
- Control the actuator to extend and retract by swapping the DC input polarity.
- Synchronous control requires the actuator to have any positioning function among POT, single Hall and dual Hall.
- If the actuators have no positioning function, they must have the stroke limit switches at both ends to stop by themselves.

## Ordering Key

ACI72 - 0

### Option

**0:** PCBA only

**R:** DIN rail can be attached

Tel: +31 (0)85 0668800  
Mail: [verkoop@aamotionandcontrol.nl](mailto:verkoop@aamotionandcontrol.nl)  
[www.aamotionandcontrol.nl](http://www.aamotionandcontrol.nl)



#### Terms of Use

The user is responsible for application suitability of A&A Motion and Control products. As ongoing improvement process continues, products listed on the A&A Motion and Control website are subject to change without prior notice. Moteck reserves the right to terminate the sales or remove any product displayed on the website, or listed in its catalogues.