

Actuator

AIA05

AIA05 is a high speed AC powered linear actuator designed with stainless steel extension tube (ball screw version), which is suitable for various outdoor industrial applications, such as construction machine, air bridge, mining transportation conveyor... etc. It also features its heavy load capability and low current deviation. Ball Screw or ACME spindle is available for users to choose.



Feature

- Main applications: Industrial
- Input voltage: 115V AC / 60Hz ; 230V AC / 50Hz
- Max. rated load: 3,500N (ACME) / 7,000N (Ball Screw)
- Max. static load: 4,500N (ACME) / 13,600N (Ball Screw)
- Typical speed at no load: 52.8 mm/sec
- Stroke: 102 ~ 610 mm
- IP Protection level: IP65
- Overload protection by clutch
- Extension tube material: Iron (for ACME) or stainless steel (for Ball Screw)
- Color: Black
- Power cord length: 600 mm (with tinned wires)
- Duty cycle: 25%, max. 4 min. continuous operation in 16 min.
- Ambient operation temperature: -25°C ~ +65°C
- Certified: UL E362815, CE marking, EMC Directive 2014/30/EU

Option

- Analog and absolute positioning feedback with Potentiometer (POT)
- Preset limit switches (LT), to stop motor automatically at both stroke ends by cutting power.
- IP Protection level: IP65
- Mounting bracket (MB30) (Fig.1)
- Longer power cord



Fig. 1

Performance Data

ACME type

• 115V AC

Model No.	Gear ratio	Push / Pull Max. (N)	*Typical Speed (mm/s)		*Typical Current (A)	
			No load	Full load	No load	Full load
AIA05-115-10-A-XXX	10:1	1500	26.5	22.9	2.8	3.1
AIA05-115-20-A-XXX	20:1	2500	13.1	11.8	2.7	2.7
AIA05-115-40-A-XXX	40:1	3500	6.6	6.0	2.7	2.7

Speed vs. Load

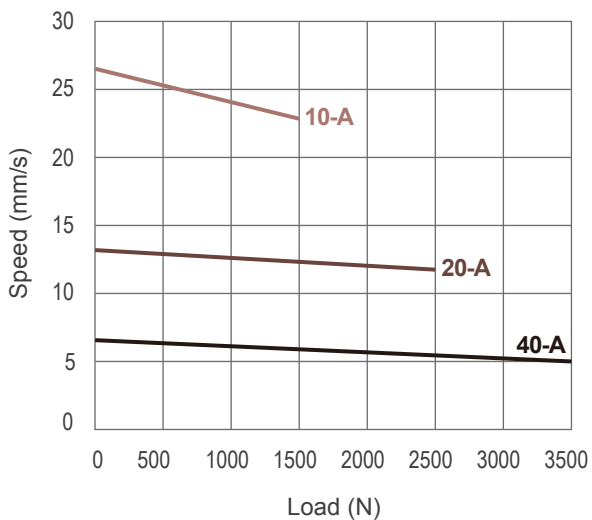

Current vs. Load

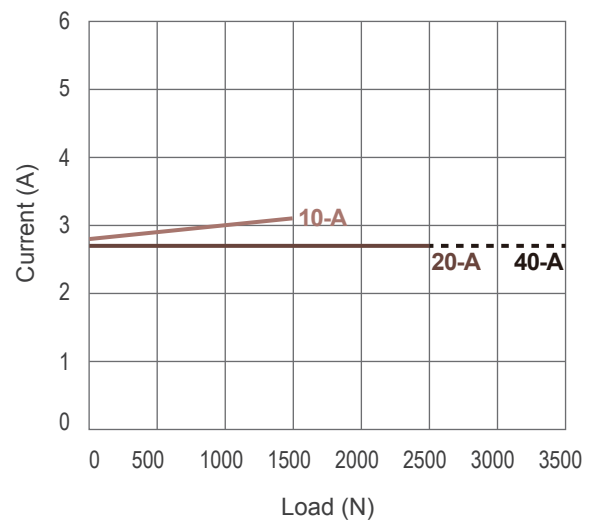

● 230V AC

Model No.	Gear ratio	Push / Pull Max. (N)	*Typical Speed (mm/s)		*Typical Current (A)	
			No load	Full load	No load	Full load
AIA05-230-10-A-XXX	10:1	1500	21.8	17.5	1.8	1.8
AIA05-230-20-A-XXX	20:1	2500	10.8	9.3	1.9	1.9
AIA05-230-40-A-XXX	40:1	3500	5.4	4.9	1.9	1.9

Speed vs. Load

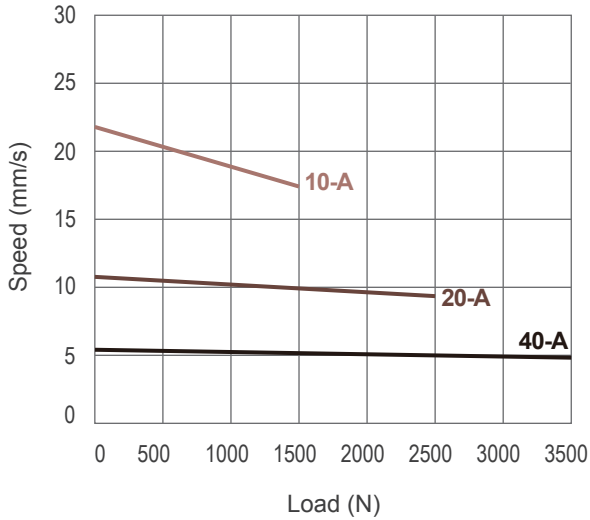

Current vs. Load

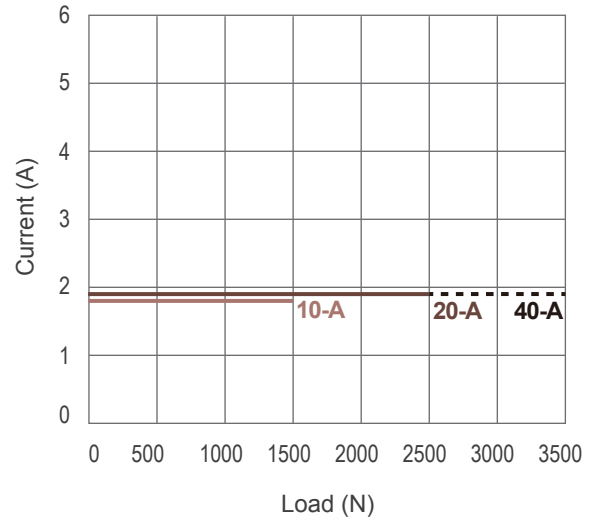

Ball Screw type

● 115V AC

Model No.	Gear ratio	Push / Pull Max. (N)	*Typical Speed (mm/s)		*Typical Current (A)	
			No load	Full load	No load	Full load
AIA05-115-05-B-XXX	5:1	2500	52.8	40.8	2.8	3.5
AIA05-115-10-B-XXX	10:1	3500	26.5	22.9	2.8	3.1
AIA05-115-20-B-XXX	20:1	4500	13.1	11.8	2.7	2.7
AIA05-115-30-B-XXX	30:1	6000	8.7	7.9	2.7	2.7
AIA05-115-40-B-XXX	40:1	7000	6.6	6.0	2.7	2.7

Speed vs. Load

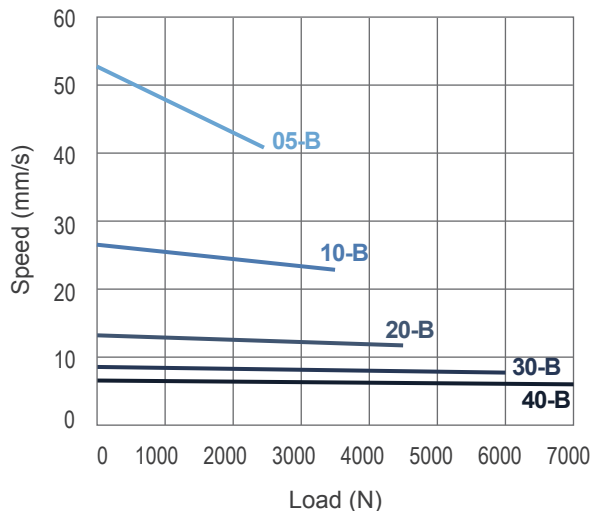

Current vs. Load

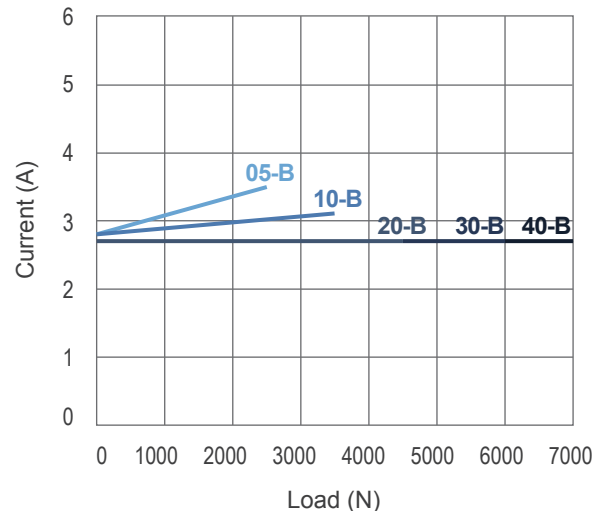

● 230V AC

Model No.	Gear ratio	Push / Pull Max. (N)	*Typical Speed (mm/s)		*Typical Current (A)	
			No load	Full load	No load	Full load
AIA05-230-05-B-XXX	5:1	2500	43.5	29.0	1.8	1.8
AIA05-230-10-B-XXX	10:1	3500	21.8	17.5	1.8	1.8
AIA05-230-20-B-XXX	20:1	4500	10.8	9.3	1.9	1.9
AIA05-230-30-B-XXX	30:1	6000	7.2	6.3	1.9	1.9
AIA05-230-40-B-XXX	40:1	7000	5.4	4.9	1.9	1.9

Speed vs. Load

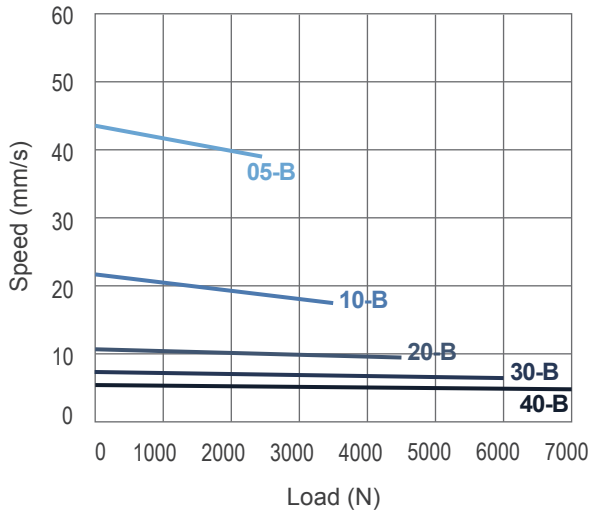

Current vs. Load

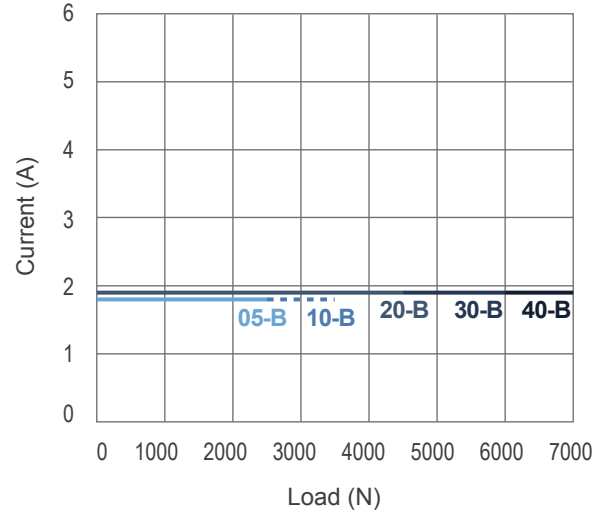

Remarks:

- * The typical speed or typical current means the average value neither upper limit nor lower limit. The performance curves are made with typical values.

Dimensions

ACME type

- Standard (without Limit switch nor Potentiometer)

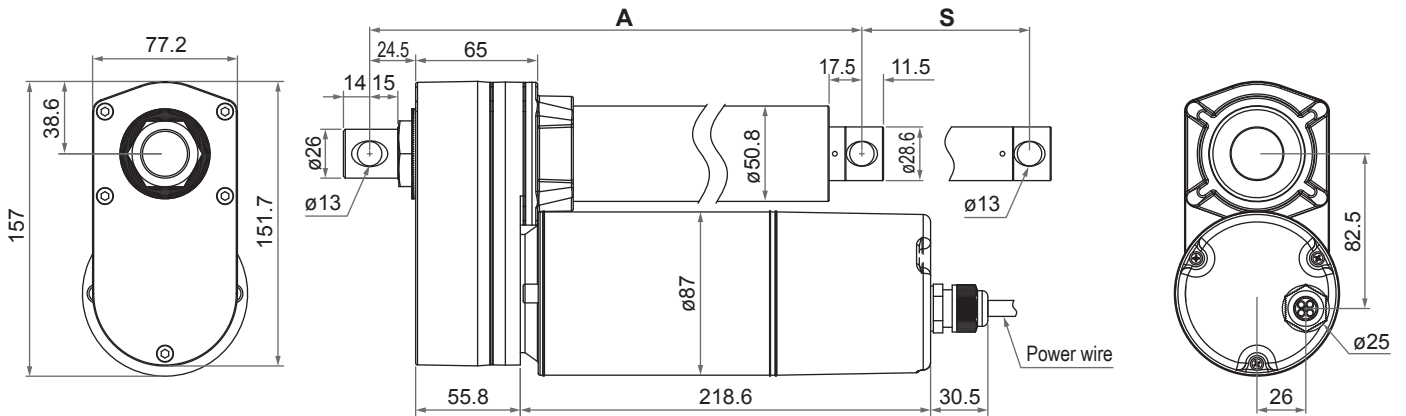

- With Limit switches (LT) or with both limit switches and Potentiometer (POT)

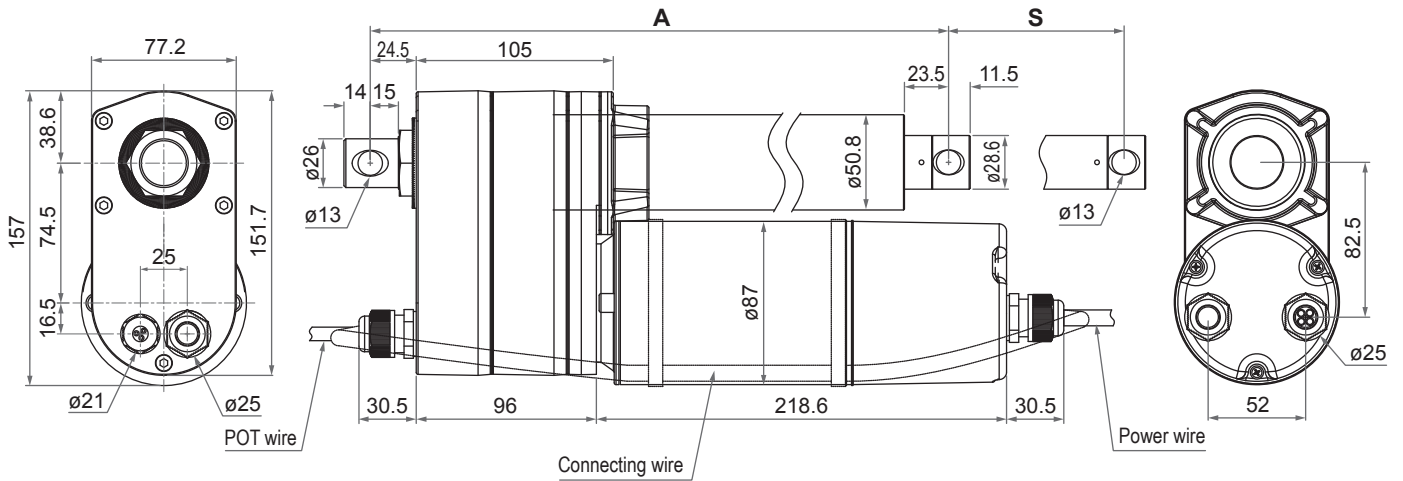

• Installation Dimension

Retracted length (A)

Option	Stroke (S)						
	102 (4")	153 (6")	203 (8")	254 (10")	305 (12")	457 (18")	610 (24")
Standard	262	313	364	414	465	668	821
LT or LT+POT	302	353	404	454	505	708	861

(tolerance: $\pm 5\text{mm}$)

Ball Screw type

- Standard (without Limit switch nor Potentiometer)

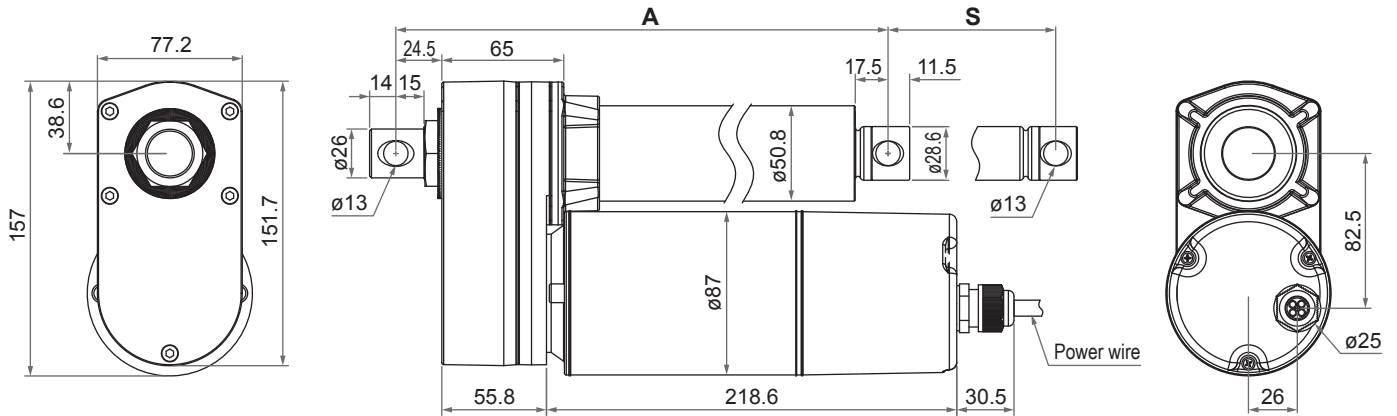

- With Limit switches (LT) or with both limit switches and Potentiometer (POT)

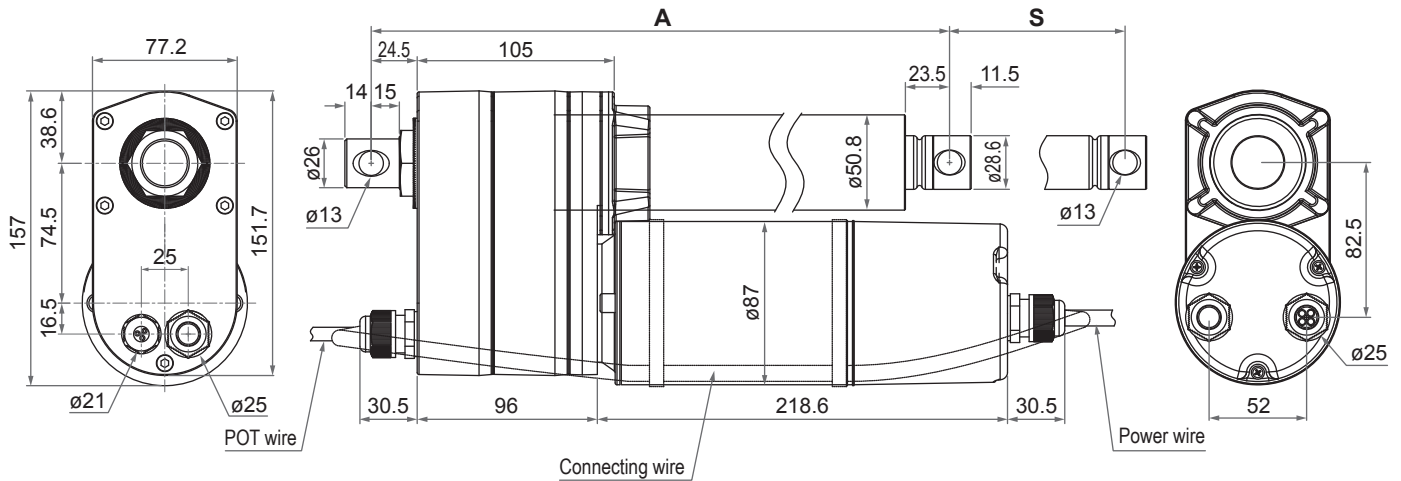

• Installation Dimension

Retracted length (A)

Option	Stroke (S)						
	102 (4")	153 (6")	203 (8")	254 (10")	305 (12")	457 (18")	610 (24")
Standard	302	353	404	455	506	735	888
LT or LT+POT	342	393	444	495	546	775	928

(tolerance: ±5mm)

● **Front connector**

ACME type

- Standard (without Limit switch nor Potentiometer)

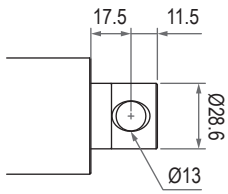

- With Limit switches (LT) or Potentiometer (POT)

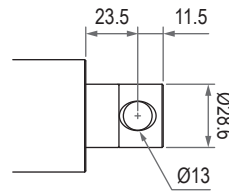

Ball Screw type

- Standard (without Limit switch nor Potentiometer)

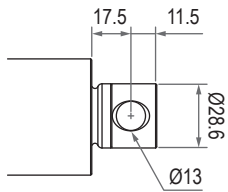

- With Limit switches (LT) or Potentiometer (POT)

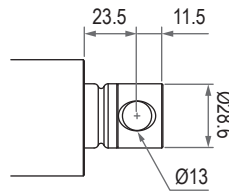

● **Rear connector**

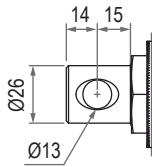

● **Pivot orientation of rear connector**

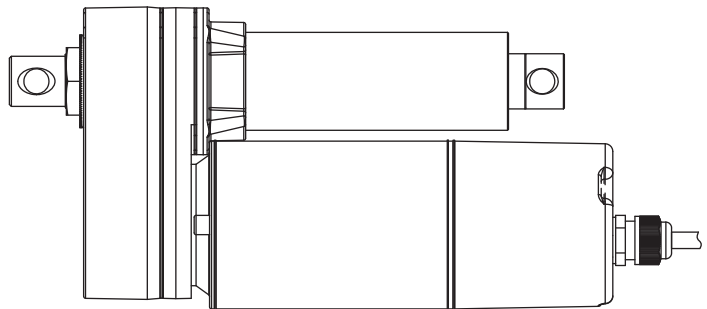
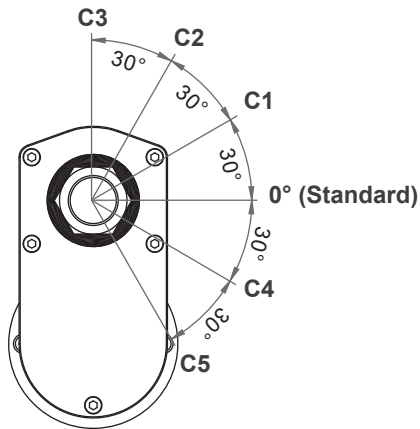

Note: As an example in 0° orientation.

● **Mounting bracket (MB30)**

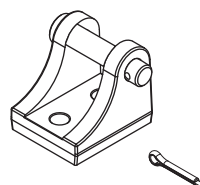
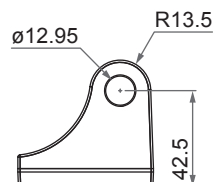
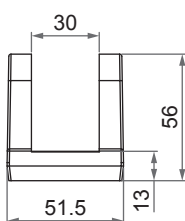
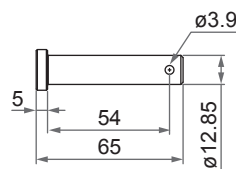
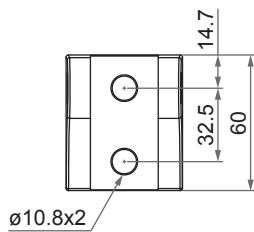

Wiring

Power wire

- **Standard or with Potentiometer (POT) type**

Gear ratio: 5:1 / 10:1 / 20:1

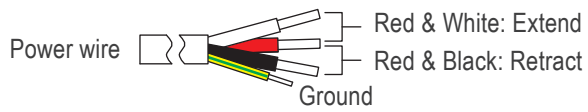

Gear ratio: 30:1 / 40:1

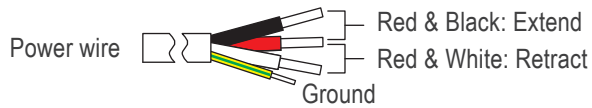

- **With Limit switches (LT) or with both limit switches (LT) and Potentiometer (POT) type**

Gear ratio: 5:1 / 10:1 / 20:1 / 30:1 / 40:1

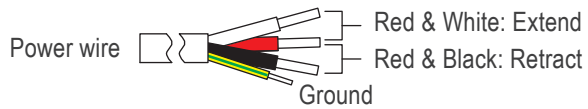

POT wire

The resistance between blue and white wires increased when the actuator extends, and decreased when it retracts.

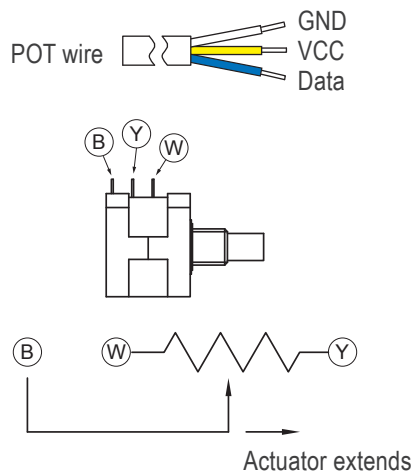

The POT value vs. stroke as shown in the table:

Stroke (mm)	Resistance ($\pm 0.3K\Omega$)
102	0.3 ~ 8.1K
153	0.3 ~ 8.7K
203	0.3 ~ 9.2K
254	0.3 ~ 7.4K
305	0.3 ~ 8.8K
457	0.3 ~ 9.4K
610	0.3 ~ 9.9K

Ordering Key

AIA05 - 230 - 20 - B - 102 - POT - LT - 0

Input voltage	115: 115V AC 230: 230V AC
Gear ratio	05: 5:1 (Ball Screw only) 10: 10:1 20: 20:1 30: 30:1 (Ball Screw only) 40: 40:1
Spindle type	A: ACME B: Ball Screw
Stroke	102: 102 mm (4") 153: 153 mm (6") 203: 203 mm (8") 254: 254 mm (10") 305: 305 mm (12") 457: 457 mm (18") 610: 610 mm (24")
Positioning feedback	Blank: None POT: Potentiometer
Option (alternative)	Blank: None LT: Limit switches IP65: IP65 Protection level
Pivot orientation of Rear connector	0: 0° (standard) C1: 30° counter-clockwise C2: 60° counter-clockwise C3: 90° counter-clockwise C4: 30° clockwise C5: 60° clockwise (Please refer to page 7)
Mounting bracket (MB30)	Blank: None M1: Mounting bracket x 1 M2: Mounting bracket x 2 (Please refer to page 7)

Tel: +31(0)30 6081717
Mail: verkoop@aamotionandcontrol.nl
www.aamotionandcontrol.nl

Terms of Use

The user is responsible for application suitability of A&A Motion and Control products. As ongoing improvement process continues, products listed on the A&A Motion and Control website are subject to change without prior notice. A&A Motion and Control reserves the right to terminate the sales or remove any product displayed on the website, or listed in its catalogues.